

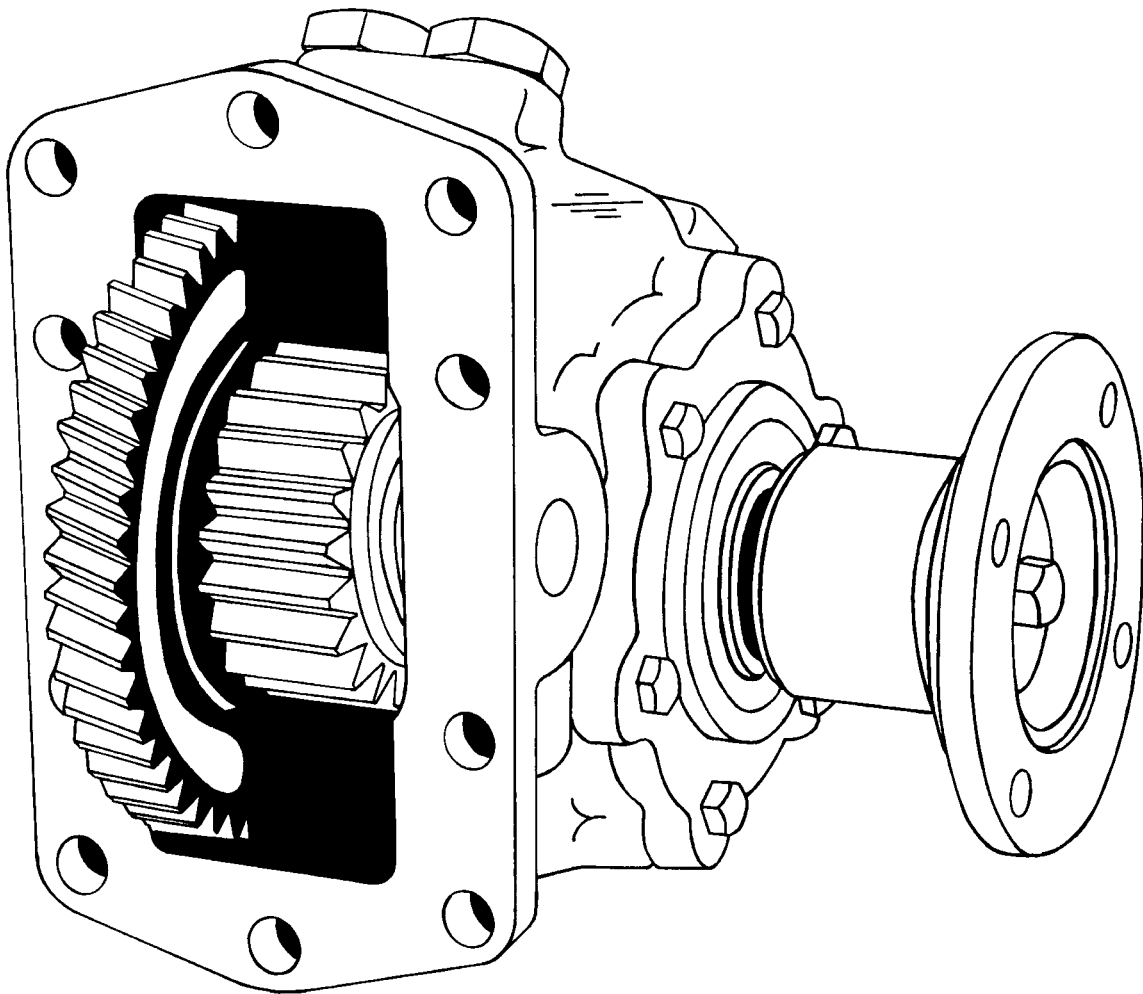

CD10 SERIES PTO

PARTS LIST AND SERVICE MANUAL



HEAVY DUTY, CONSTANT DRIVE PTO
FOR THE ALLISON WORLD TRANSMISSION

CD10 SERIES PTO - EXPLODED VIEW

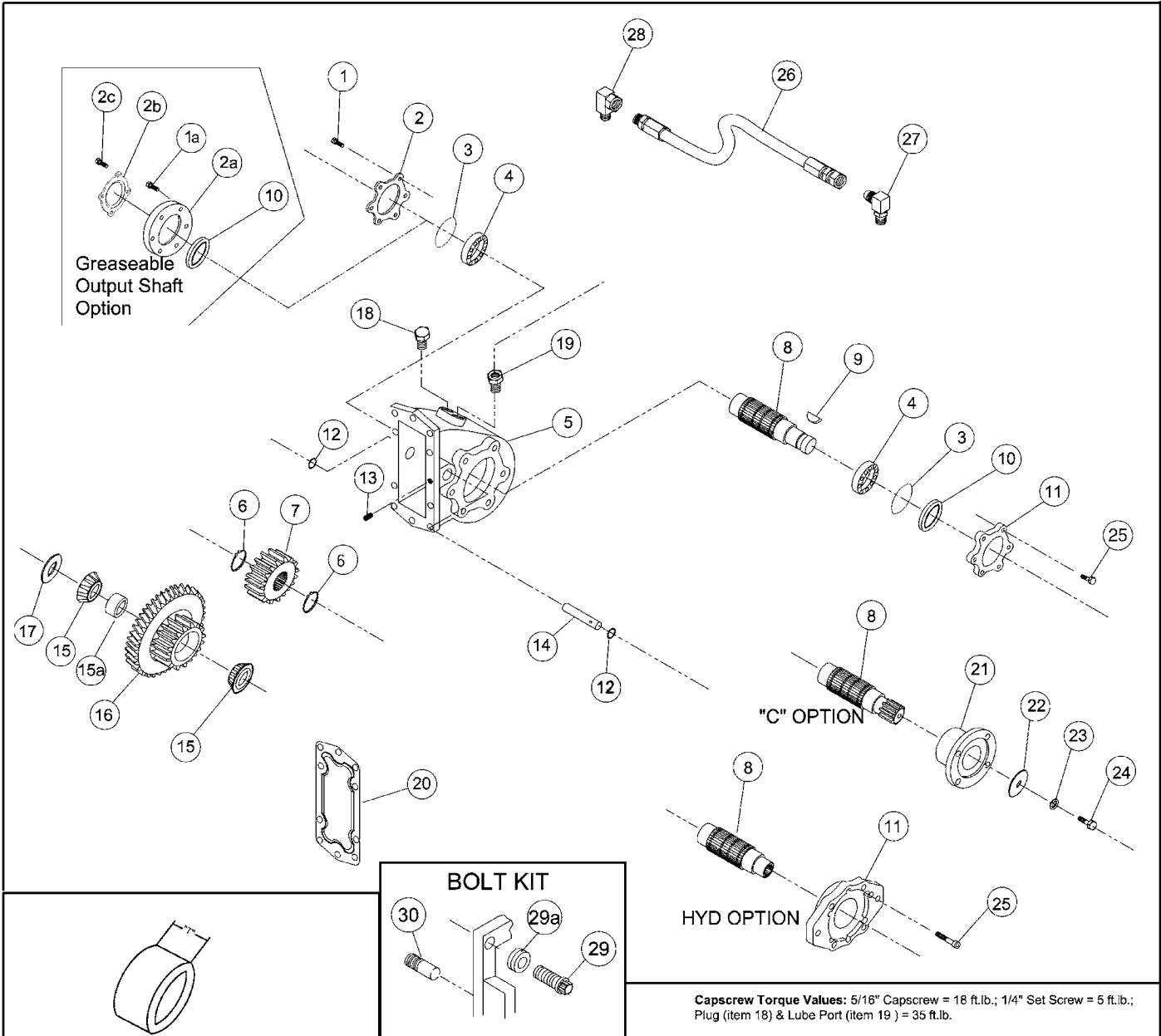

Capscrew Torque Values: 5/16" Capscrew = 18 ft.lb.; 1/4" Set Screw = 5 ft.lb.; Plug (item 18) & Lube Port (item 19) = 35 ft.lb.

ITEM 15A CONE SPACER

"T"

PART NO	DESCRIPTION	DIMENSION
18T38748	Cone Spacer	0.743 / 0.741
18T38532	Cone Spacer	0.740 / 0.738
18T38533	Cone Spacer	0.737 / 0.735
18T38534	Cone Spacer	0.734 / 0.732
18T38535	Cone Spacer	0.731 / 0.729
18T38536	Cone Spacer	0.728 / 0.726
18T38537	Cone Spacer	0.725 / 0.723
18T38538	Cone Spacer	0.722 / 0.720
18T38539	Cone Spacer	0.719 / 0.717
18T38540	Cone Spacer	0.716 / 0.714
18T38590	Cone Spacer	0.713 / 0.711
18T38591	Cone Spacer	0.710 / 0.708
18T38592	Cone Spacer	0.707 / 0.704

CONE SPACER INSTALLS BETWEEN THE TAPERED INPUT BEARINGS TO SET THE BEARING PRELOAD AT .002"-.006" LOOSE.
CRITICAL DIMENSION. PURCHASE **INPUT GEAR ASSEMBLY** (ITEM 16) WHICH INCLUDES THE CORRECT CONE SPACER.

BOLT KIT

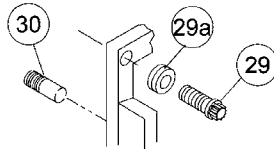

ITEM 16 GEAR ASSEMBLY

ASSY NO.	DESCRIPTION	BASE GEAR
03TA4624	A1005 Input Gear (50/21)	03T35752
03TA4625	A1006 Input Gear (50/23)	03T35919
03TA4626	A1007 Input Gear (50/25)	03T35755
03TA4627	A1008 Input Gear (50/27)	03T35758
03TA4628	A1010 Input Gear (50/29)	03T35761
03TA4629	A1012 Input Gear (50/32)	03T36545
03TA4630	A1015 Input Gear (50/35)	03T38830
03TA4978	C9505 Input Gear (45/21)	03T40237
03TA4979	C9506 Input Gear (45/23)	03T40217
03TA4980	C9507 Input Gear (45/25)	03T40218
03TA4981	C9508 Input Gear (45/27)	03T40219
03TA4982	C9510 Input Gear (45/29)	03T40220
03TA4983	C9512 Input Gear (45/32)	03T40221
03TA4984	C9515 Input Gear (45/35)	03T40222

ITEM 17 SPACER

PART NO	DESCRIPTION	DIMENSION
18T35783	BRG SPACER	0.1150 / 0.1130
18T38725	BRG SPACER	0.1175 / 0.1155
18T35782	BRG SPACER	0.1200 / 0.1180
18T38726	BRG SPACER	0.1225 / 0.1205
18T35781	BRG SPACER	0.1250 / 0.1230
18T38727	BRG SPACER	0.1275 / 0.1255
18T36230	BRG SPACER	0.1300 / 0.1280
18T38728	BRG SPACER	0.1325 / 0.1305
18T36229	BRG SPACER	0.1350 / 0.1330
18T38729	BRG SPACER	0.1375 / 0.1355
18T37151	BRG SPACER	0.1400 / 0.1380
18T38730	BRG SPACER	0.1425 / 0.1405
18T37152	BRG SPACER	0.1450 / 0.1430
18T38731	BRG SPACER	0.1475 / 0.1455
18T37153	BRG SPACER	0.1500 / 0.1480

WITH INPUT GEAR AND BEARINGS SET IN HOUSING DRIVE IDLER SHAFT THROUGH BOTH TAPERED BEARINGS AND CONE SPACER. DRIVE IDLER SHAFT EVEN WITH BEARING SURFACE. SELECT THE LARGEST SHIM THAT FITS BY HAND, THEN REMOVE SHIM AND SELECT NEXT LARGER SHIM, MAY REQUIRE SHIM TO BE DRIVEN INTO PLACE.

PARTS LIST AND DESCRIPTION

ITEM	QTY	PART NO.	DESCRIPTION
1	6	19T32740	Hex Capscrew
1a	6	19T39601	Capscrew Feat. "G"
2	1	15T35772	Bearing Cover, Closed
2a	1	15T39026	Cover - Feature "G"
2b	1	15T34323	Shaft Cover Feature "G"
2c	4	19T33134	Capscrew Feature "G"
3	2	12T35773	O-ring
4	2	10T35775	Bearing
5	1	01T35750	Housing
6	2	24T26980	Snap Ring
7			OUTPUT GEAR
	1	02T35753	05 Ratio (38T)
	1	02T35920	06 Ratio (36T)
	1	02T35756	07 Ratio (34T)
	1	02T35759	08 Ratio (32T)
	1	02T35762	10 Ratio (30T)
8			OUTPUT SHAFT
	1	06T35972	"B" Standard 1-1/4 Rd
	1	06T35763	"C, X & Z" 1-1/2 10 Spl.
	1	06T35764	"D, Q, S" SAE "B" 7/8 13 Spl.
	1	06T35765	"Y & Z" SAE "C" 1-1/4 14 Spl.
	1	06T36831	"I" DIN 5462 36mm 8 Spl.
	1	06T37187	"P" SAE "BB" 2 & 4 Bolt
	1	06T37723	"R" SAE "A" 5/8 9 Spl.
8			OUTPUT SHAFT FEATURE G
	1	06T38264	"DG, SG" Greaseable SAE-B
	1	06T37374	"IG" Greaseable DIN 5462
	1	06T38197	"PG" Greaseable SAE-BB
	1	06T40647	"ZG, YG" Greaseable SAE-C
9	1	26T01627	Woodruff Key ("B" Only)
10	1	11T37795	Output Shaft Seal
11			BEARING COVER
	1	15T35770	Bearing Cover "B", "C"
	1	14T35767	"D, P & Z" Hydraulic Flange
	1	14T36834	"I" Hydraulic Flange STD
	1	14T39570	"IG" Hydraulic Flange Requires Breather 44M30137 "IG" Only
	1	14T37724	"R, Q" Hydraulic Flange
	1	14T37474	"S" Hydraulic Flange
	1	14T36007	"Y" Hydraulic Flange
12	2	12T35774	O'ring
13	1	19T35785	Set Screw
14	1	07T35780	Idler Shaft
15	2	10T35776	Bearing
15		See Chart on Page 2	Cone Spacer
16			INPUT/RATIO GEAR
		See Chart on Page 2	Input Gear Assembly

ITEM	QTY	PART NO.	DESCRIPTION
17		See Chart on Page 2	Bearing Shim
18	1	25T35999	Plug
19	1	25T35784	Lubrication Port
20	1	13T35777	Gasket/Shim
21	1	14T31499	Companion Flange (1410)
	1	14T37498	Companion Flange DIN 100
22	1	21T20092	Flat Washer
24	1	19T38266	Capscrew
25	6	19T32740	Capscrew "C, 2, B" Output
	6	19T31577	Capscrew "D, Q, S, P, Z" Hyd. Assy.
	6	19M84478	Capscrew "Y, R, S" Hyd. Assy
	6	19T25386	Capscrew "I" Hyd. Assy.
	6	19T39601	Capscrew "IG" Hyd. Assy
			43MK2810 PRESSURE LUBE KIT FEATURE "X" INCLUDES
26	1	45M4R528	Hose Assembly
27	1	43M68014	Hydraulic Adapter
28	1	43M05522	Hydraulic Adapter
			43MK3620 PRESSURE LUBE KIT FEATURE "B" INCLUDES
26	1	45M4R548	Hose Assembly
27	1	43M68014	Hydraulic Adapter
28	1	43M05522	Hydraulic Adapter
			43TK4545 PRESSURE LUBE KIT FEATURE "3" INCLUDES
26	1	45T39186	Hose Assembly
27	1	43M68014	Hydraulic Adapter
28	1	43T36445	Hydraulic Adapter
			20MK1001 MOUNTING BOLT KIT INCLUDES
29	6	19T40226	12Pt. Metric Screw 30mm
	2	19T37727	12Pt. Metric Screw 25mm
29a	6	21T40360	Lock Washer Device
30	2	20T35779	Alignment Stud - Metric
NS	1	43T37236	Grease Zerk
NS	1	25T35724	Cap Plug "D" Hyd. Only
	1	25T35936	Cap Plug "Y" Hyd. Only
NS	1	36MK3841	Label Packet (English)
	1	36MK3842	Label Packet (Spanish)
NS	1	52MK1010	Gasket Kit & Instructions Includes (1) Item 20
NS	1	31TK3873	Pulse Gen. Kit ("U" Option)
NS	1	CD-GSK Gasket Kit -	Includes: 2 (3), 1 (10), 2 (12), 1 (20)
NS	1	CD-RBK Rebuild Kit -	Includes: 2 (3), 2 (4), 2 (6), 1 (10), 2 (12), 2 (15), 3 (17), 1 (20)

** Item numbers 15, 16 and 17 require a total end play adjustment of +0.002 (loose) to +0.006(loose). This should be done by placing both bearing cones into the gear assembly, then into the housing, and quickly counter-rotating the gear to seat the bearings, then measuring the overall space available for the proper shim part number selection (item #17). Shim is to be installed on input gear side as shown.

Torque Values: 5/16" Capscrew - 18 ft.lb.; 1/4" Set Screw - 5 ft.lb.; Plug (item #18) & Lube Port (item #19) - 35 ft.lb.

CD10 MODEL NUMBER CONSTRUCTION

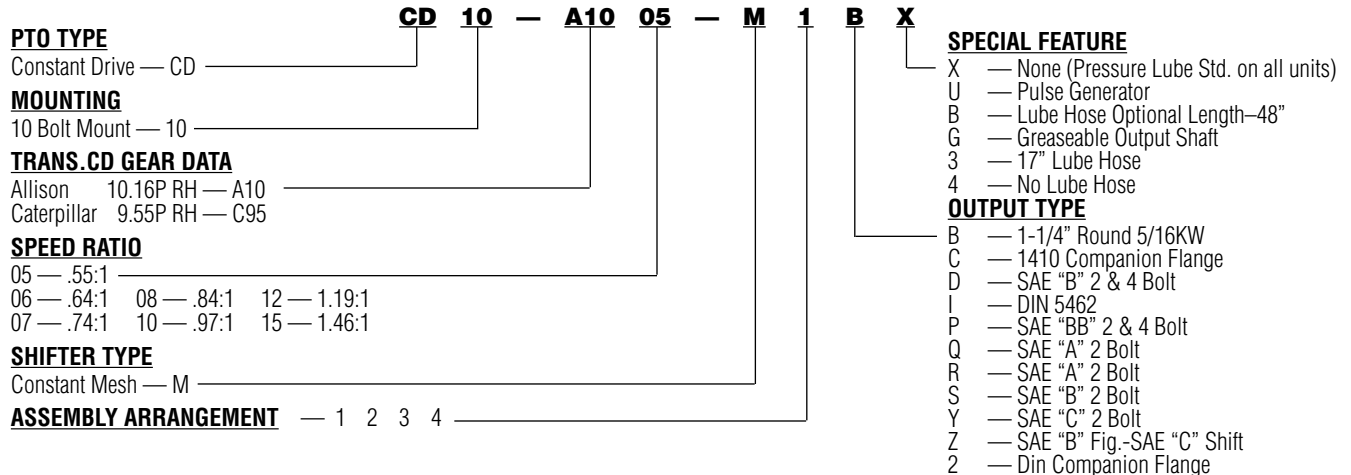

CD10 DIMENSIONS - IN INCHES (MM)

<p>C-OPTION 1410 COMP FLG</p> <p>1410 SERIES - 1-1/2 10 SPL. 2-3/4 [70] PILOT 3-3/4" [95.1] B.C.</p> <p style="text-align: center;">1-Arrg 3-Arrg</p>	<p>D-OPTION SAE B</p> <p>7/8 13T SPLINE 2-BOLT 1/2-13 UNC - 5.75[146.0] B.C. 4-BOLT 1/2-13 UNC - 5.0[127.0] B.C.</p> <p style="text-align: center;">DG 1-Arrg 3-Arrg</p>
<p>P-OPTION SAE B-B</p> <p>1" 15T SPLINE 2-BOLT 1/2-13 UNC - 5.75[146.0] B.C. 4-BOLT 1/2-13 UNC - 5.0[127.0] B.C.</p> <p style="text-align: center;">PG 1-Arrg 3-Arrg</p>	<p>Z-OPTION SAE B FLG W/SAE-C SHAFT</p> <p>1-1/4-14T INV. SPLINE 2-BOLT 1/2-13 UNC 5.75[146.0] B.C. 4-BOLT 1/2-13 UNC 5.0[127.0] B.C.</p> <p style="text-align: center;">ZG 1-Arrg 3-Arrg</p>
<p>S-OPTION SAE B</p> <p>7/8 13T SPLINE 2-BOLT 1/2-13 UNC - 5.75[146.0] B.C.</p> <p style="text-align: center;">SG 1-Arrg 3-Arrg</p>	<p>Z-OPTION SAE B FLG W/SAE-C SHAFT</p> <p>1-1/4-14T INV. SPLINE 2-BOLT 1/2-13 UNC 5.75[146.0] B.C. 4-BOLT 1/2-13 UNC 5.0[127.0] B.C.</p> <p style="text-align: center;">ZG 1-Arrg 3-Arrg</p>
<p>R-OPTION SAE A</p> <p>5/8" 9T INV. SPLINE 3/16-16UNC - 4.19[106.4] B.C.</p> <p style="text-align: center;">1-Arrg 3-Arrg</p>	<p>I-OPTION DIN 5462</p> <p>8X32X36 SPLINE 12mm x 1.75 - 113.15mm B.C.</p> <p style="text-align: center;">1-Arrg 3-Arrg</p>
<p>Q-OPTION SAE A W/SAE B SHAFT</p> <p>7/8" 13T INV. SPLINE 3/16-16UNC - 4.19[106.4] B.C.</p> <p style="text-align: center;">1-Arrg 3-Arrg</p>	<p>IG-OPTION DIN 5462/GREASEABLE</p> <p>8X32X36 SPLINE 12mm x 1.75 - 113.15mm B.C.</p> <p style="text-align: center;">1-Arrg 3-Arrg</p>
<p>B-OPTION 1-1/4 ROUND WITH 5/16 K.W.</p> <p style="text-align: center;">1-Arrg 3-Arrg</p>	<p>2-OPTION DIN COMP FLG</p> <p>DIN COMPANION FLG - 1-1/2" 10 SPL. 2.24" [57.0] PILOT 3.31" [84.0] B.C.</p> <p style="text-align: center;">1-Arrg 3-Arrg</p>



SP93-04 (Rev. 7-07) Printed in the U.S.A.
© Muncie Power Products, Inc. 2007

Muncie Power Products, Inc. Member of the Interpump Hydraulics Group
General Offices and Distribution Center • P.O. Box 548 • Muncie, IN 47308-0548
(765) 284-7721 • FAX (765) 284-6991 • E-mail info@munciepower.com
Web site <http://www.munciepower.com>

Drive Products, Exclusive Agents for Canada, ISO Certified by an Accredited Registrar

