

BRADEN®

HP50

MATERIAL LIST

NOTE: Several “running” changes have been made to the hydraulic motor group and its hoses and fittings. These were done to implement product improvements. ALWAYS include the winch serial number and complete model code when inquiring or ordering parts.

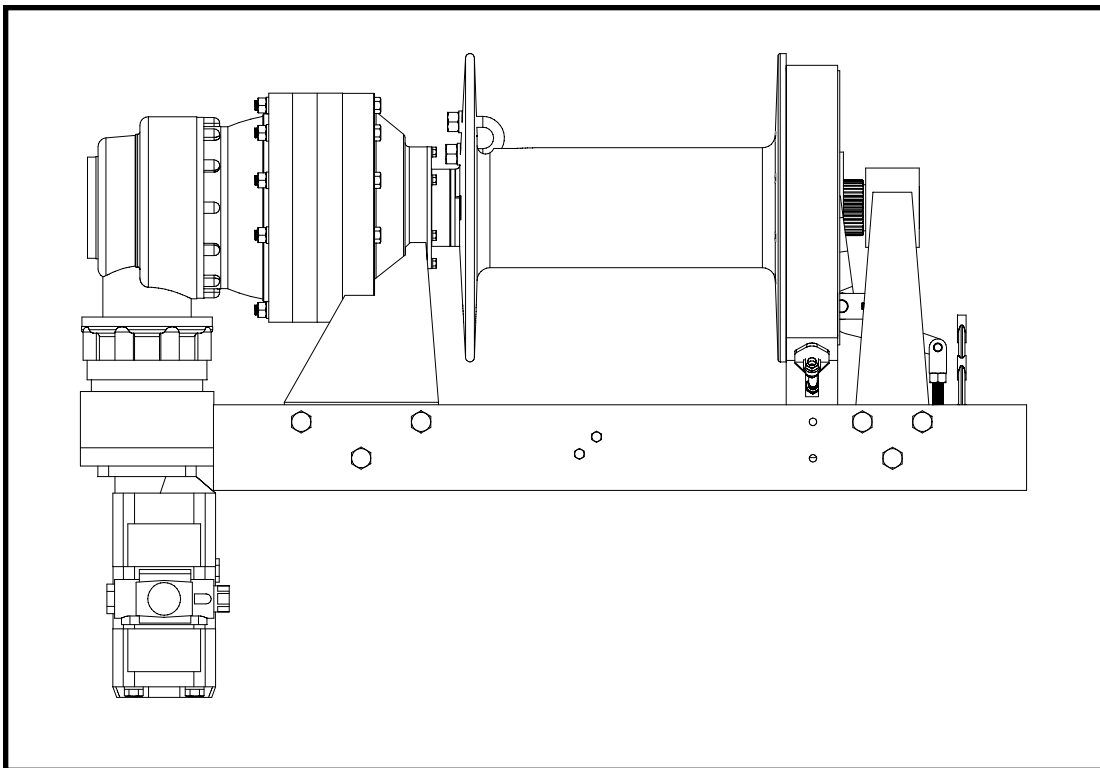

PACCAR WINCH DIVISION

P. O. BOX 547 BROKEN ARROW, OK U.S.A. 74013

PHONE (918) 251-8511 FAX (918) 259-1575

www.paccarwinch.com

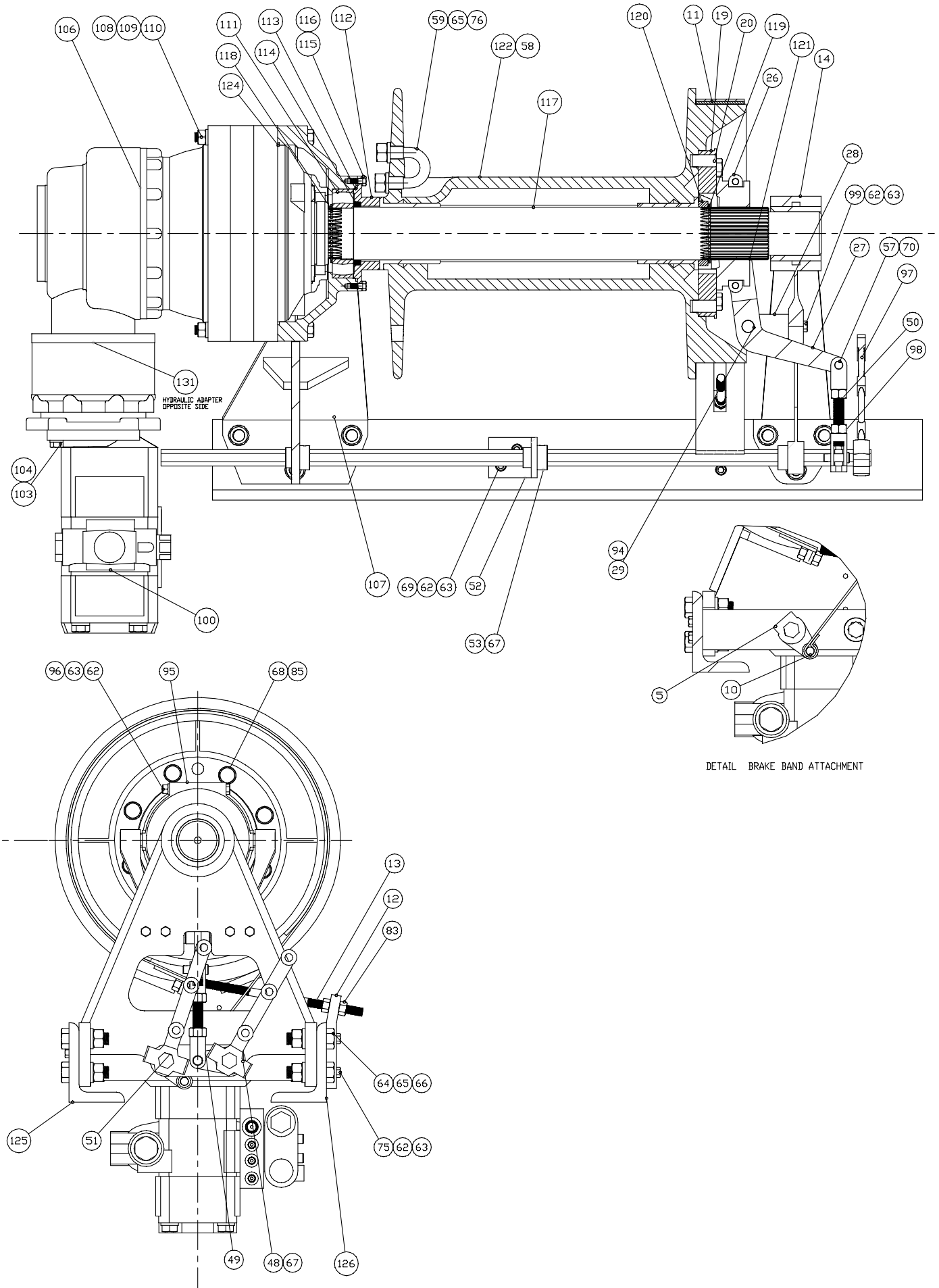

BASIC WINCH PARTS			
Item No.	Description	Part No.	Qty.
5	Brake Lever	11678	1
10	Brake Band Pin	11569	1
11	Brake Band Assembly	81590	1
12	Brake Band Link Bracket	11499	1
13	Brake Band Link	11570	1
14	Bearing Leg Assy. (with bushing)	81032	1
19	Clutch Plate	11216	1
20	Dowel Pin	12769	2
26	Clutch Rider	11671	1
27	Clutch Shifter Fork	11673	1
28	Clutch Shifter Bracket	11656	2
29	Pivot Pin	11657	1
48	Clutch Lever	11676	1
49	Clevis	11578	2
50	Clevis Link	11583	1
51	Control Shaft	11482	2
52	Bracket	11503	1
53	Collar Bushing	11669	6
57	Clevis Pin	12751	2
58	Cable Drum Grease Fitting	18047	2
59	Cable Clamp	29036	1
62	Hex Nut (3/8)	11780	12
63	Lockwasher (3/8)	18003	12
64	Capscrew (3/4 - 16 X 2 1/2 G8)	23929	12
65	Lockwasher (3/4)	13435	14
66	Hex Nut (3/4)	23930	12
67	Setscrew	13957	8
68	Capscrew (5/8 - 11 X 1 3/4 G5)	22362	8
69	Capscrew (3/8 - 16 X 1 1/2 G5)	22694	4
70	Cotter Pin	18008	4
75	Capscrew (3/8 - 16 X 1 13/4 G5)	22703	2
76	Jam Nut (3/4)	11791	2
83	Hex Nut (1/2)	22701	4
85	Washer (5/8 shakeproof)	13449	8
94	Cotter Pin	13959	1
95	Clutch Rider	11672	1
96	Capscrew (3/8 - 16 X 4 G5)	21477	2
97	Lever Assembly (with setscrew)	81208	2
98	Hex Nut (5/8)	22702	2
99	Capscrew (3/8 - 16 X 2 1/4 G5)	21474	4
100	Motor Sub-Assembly	-----	1
103	Capscrew (1/2 X 1 1/2 G8)	29290	4
104	Lockwasher (1/2)	11026	4
106	Right Angle Gearbox	-----	1
107	Motor End Drum Support		1
108	Capscrew (M14 X 180)	102674	10
109	Hex Nut (M14)	102675	10
110	Lockwasher (M14)	102676	10
111	Spherical Roller Bearing	102677	1
112	Bearing Cap	102682	1
113	O-Ring	10467	1
114	Seal	102683	1
115	Capscrew (5/16 - 18 X 3/4)	11763	6
116	Lockwasher (5/16)	11024	6
117	Drum Shaft	102678	1
118	Retaining Ring	102679	1
119	Retaining Ring	32093	1
120	Spacer	102680	1
121	Sliding Clutch	102681	1
122	Cable Drum (with bushings)	82847	1
124	O-Ring	72111	1
125	Base Angle (left hand)	102700	1
126	Base Angle (right hand)	102701	1
131	Hydraulic Adapter	102774	4

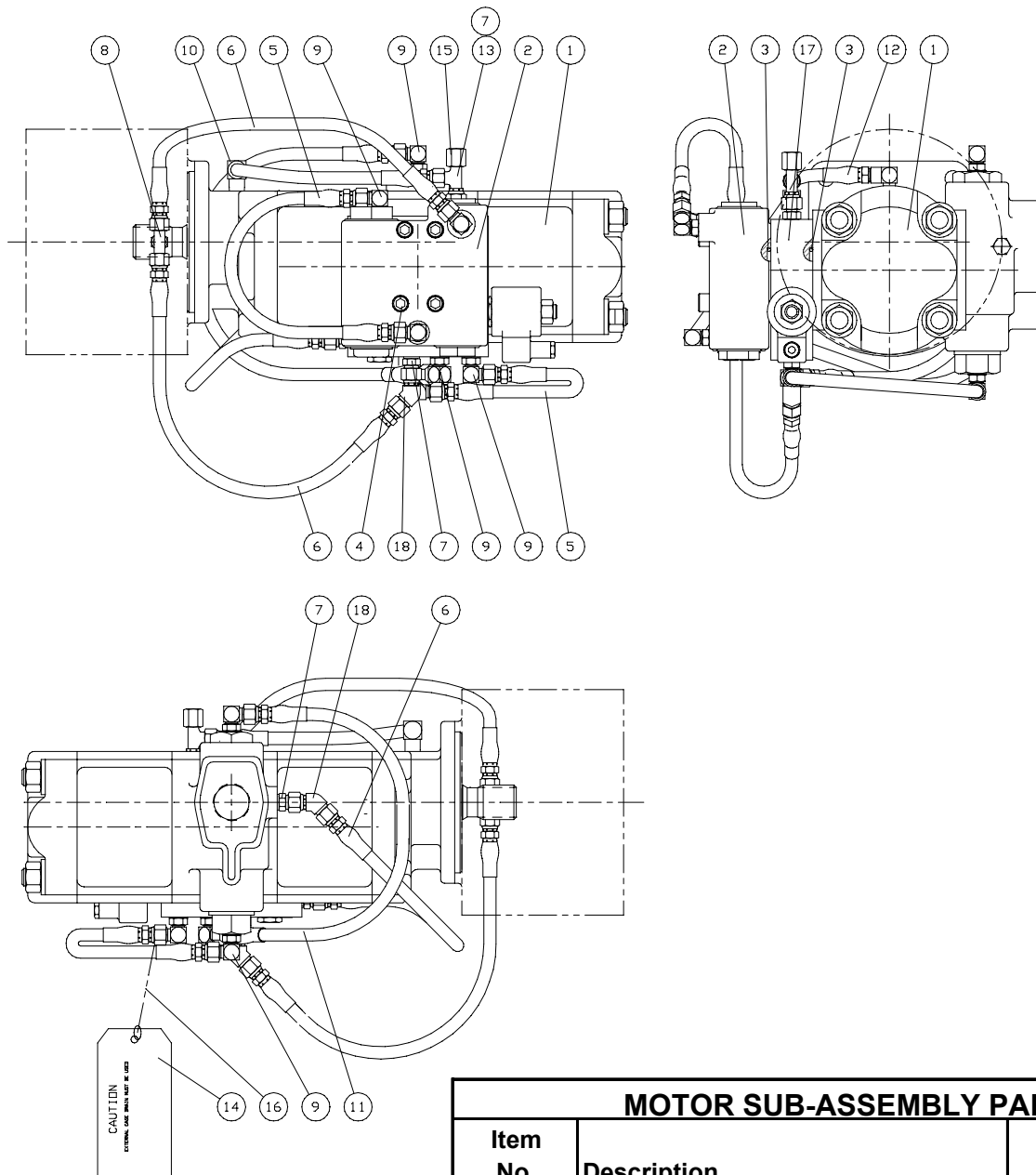

MOTOR SUB-ASSEMBLY PARTS			
Item No.	Description	Part No.	Qty.
1	2 Speed Hydraulic Motor	28956	1
2	Brake Valve	81984	1
3	O-Ring	13838	2
4	Capscrew (7/16 - 14 X 4 1/2 G8)	102476	4
5	Hose Assembly (10 in. -4 to -4)	25936	2
6	Hose Assembly (17 in.)	25750	3
7	Adapter	25864	4
8	Swivel Tee	25748	1
9	Elbow Fitting	25302	6
10	Reducer Elbow	24236	1
11	Hose Assembly (22 1/2 in.)	25749	1
12	Hose Assembly (10 in. NPT to -4)	13711	1
13	Swivel Tee	25748	1
14	Warning Tag	29080	1
15	Cap Nut	70182	1
16	Tie Wire	-----	1
17	Manifold	102922	1
18	Male Union	70122	1

OVERALL GEARBOX ASSEMBLY

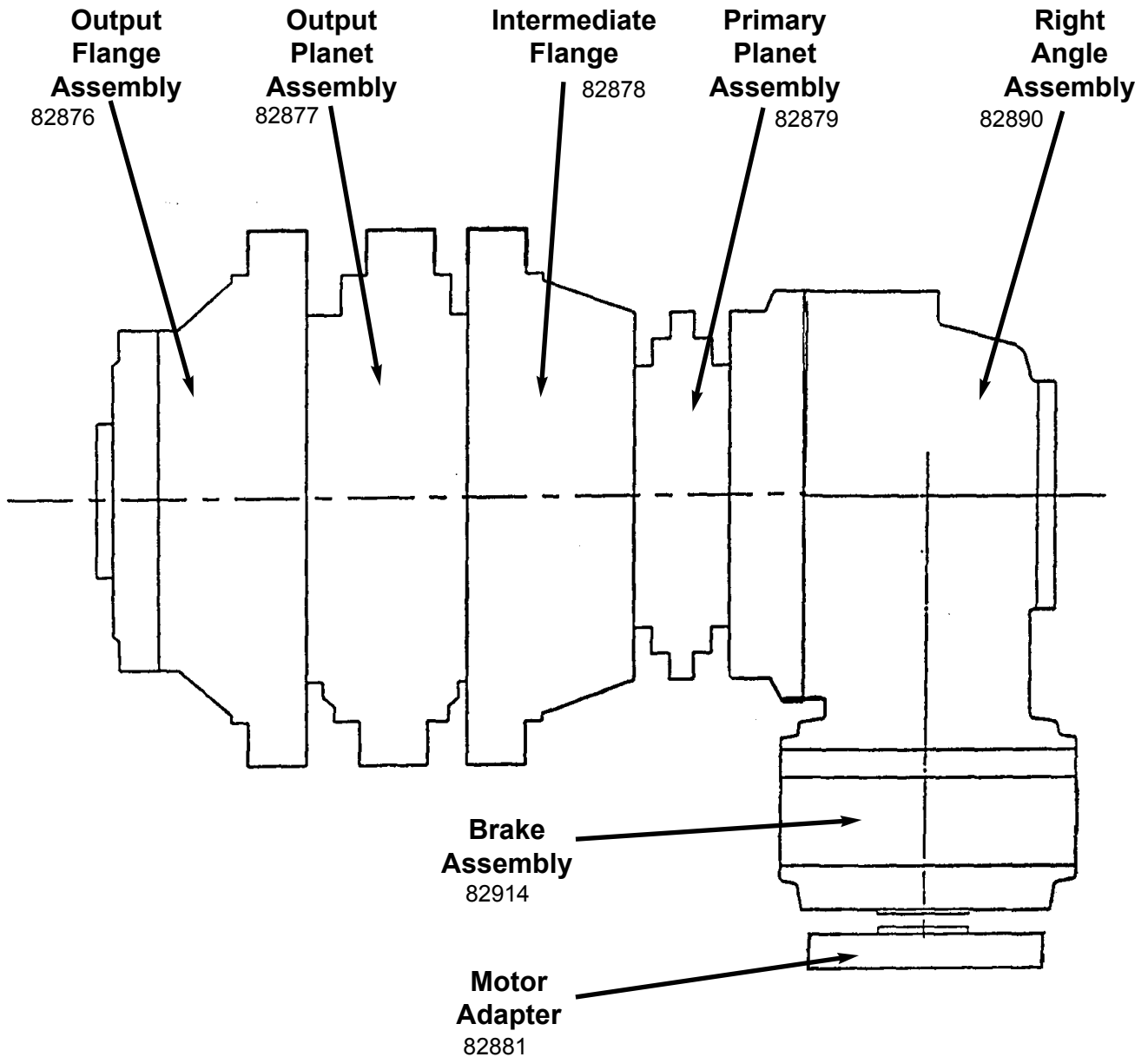

RECOMMENDED GEAR OIL

PREVAILING AMBIENT TEMPERATURE

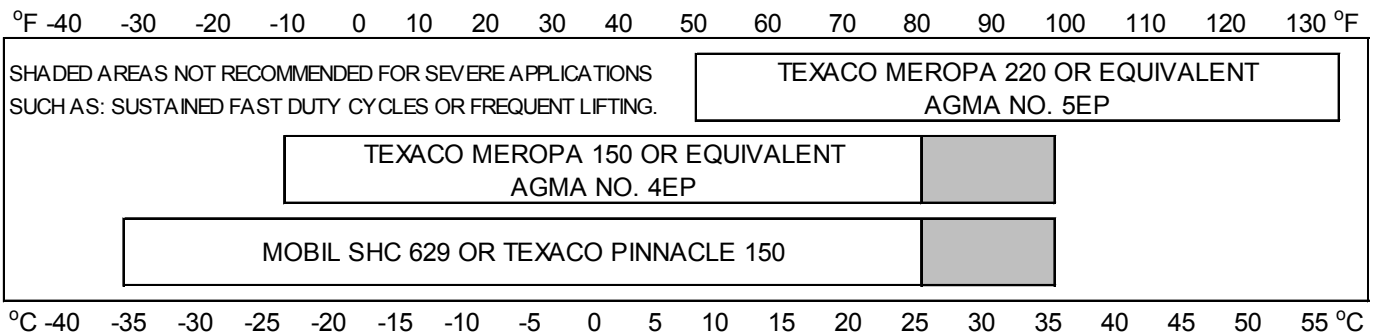

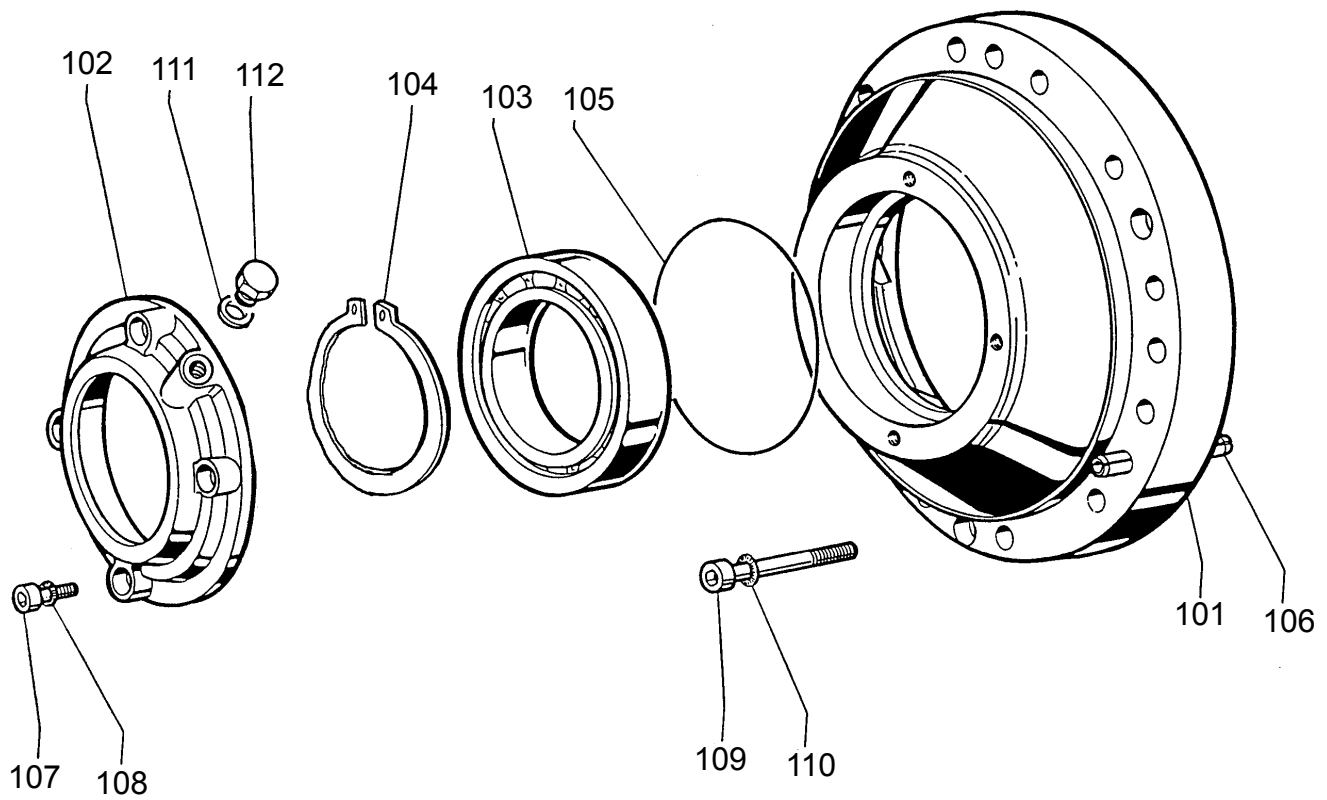

Output Flange Assembly (82876)			
Item No.	Description	Part No.	Qty.
101	Output Flange		1
102	Seal Carrier		1
103	Bearing		1
104	Retaining Ring		1
105	O-Ring		1
106	Rollpin		3
107	Capscrew		4
108	Washer		4
109	Capscrew		3
110	Washer		3
111	Washer		1
112	Plug		1

GEARBOX KITS

Seal Kit **Part No. 83009**
Bearing Kit **Part No. 82873**
Plug & Vent Kit **Part No. 82874**
Brake Repair Kit **Part No. 82875**

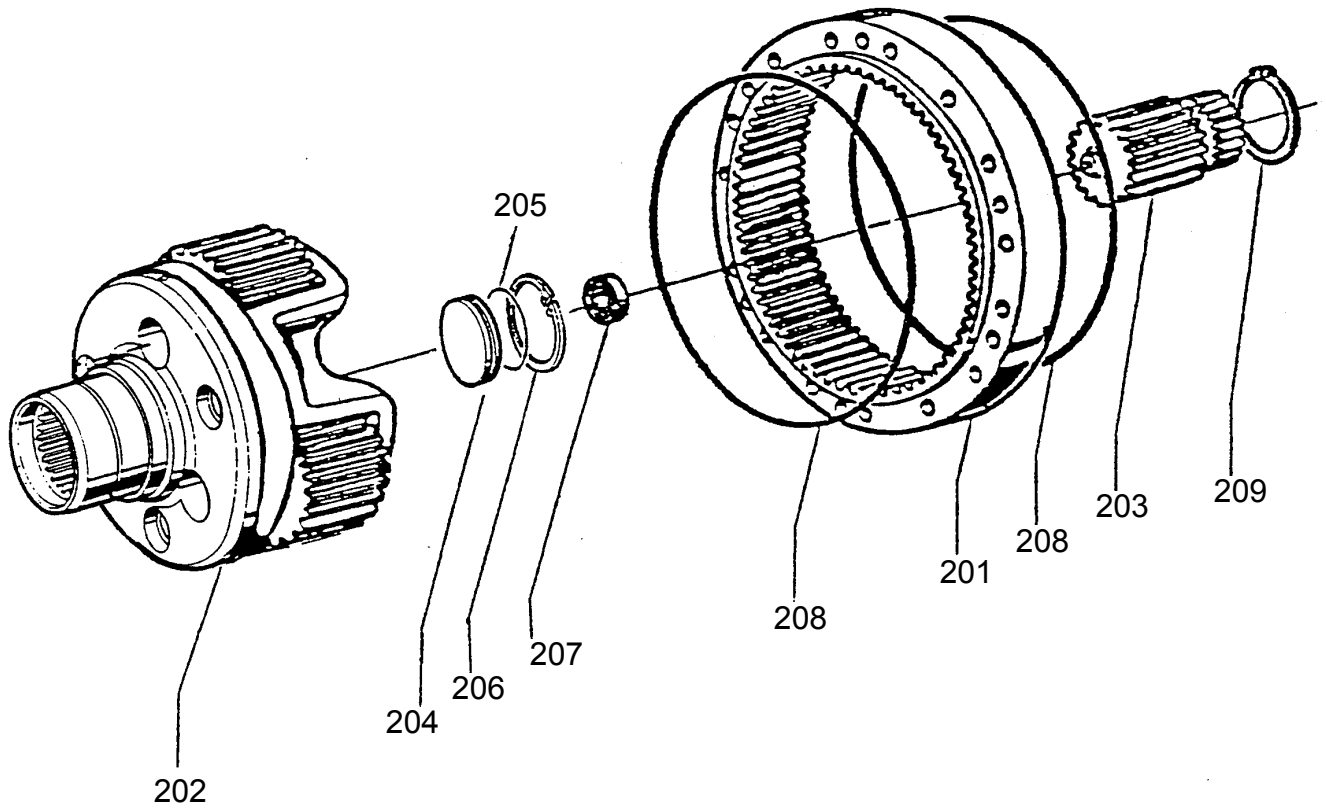

Output Planet Assembly (82877)			
Item No.	Description	Part No.	Qty.
201	Ring Gear		1
202	Output Planet Assembly		1
203	Output Sun Gear		1
204	Thrust Washer		1
205	O-Ring		1
206	Retaining Ring		1
207	Bearing		1
208	O-Ring		2
209	Retaining Ring		1

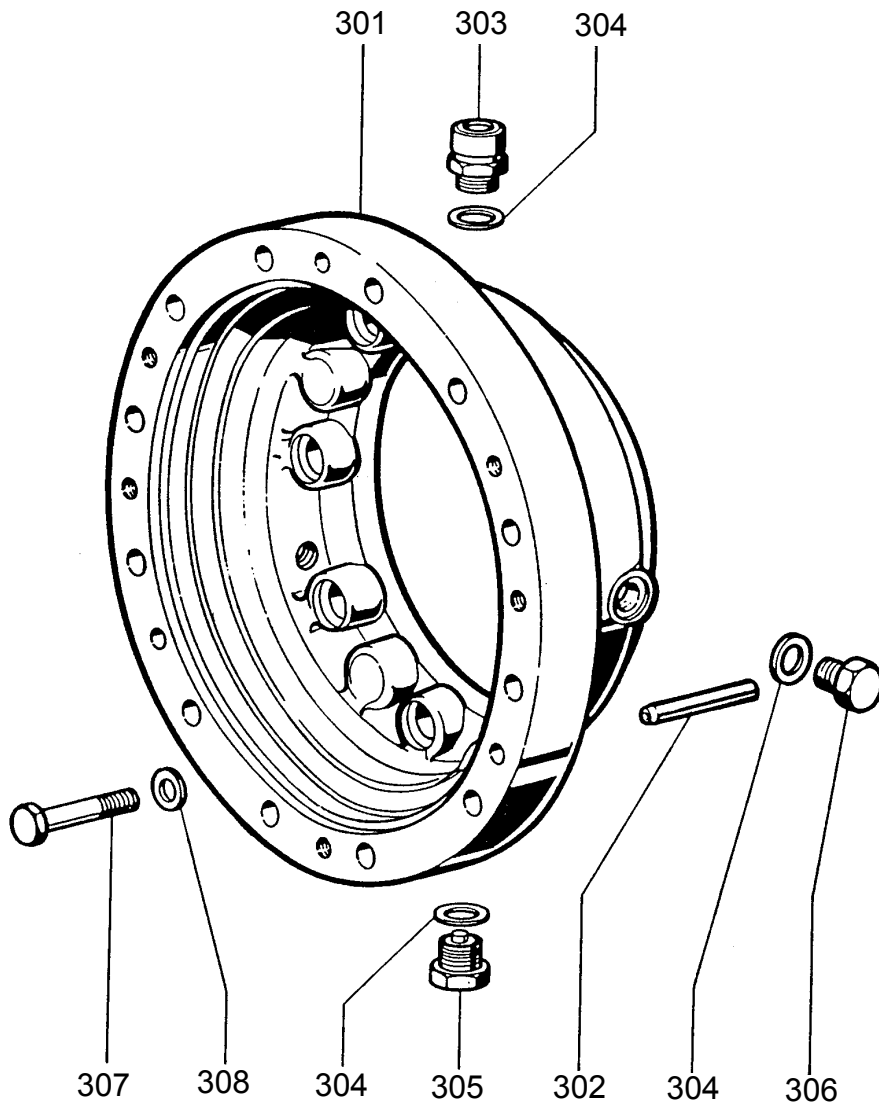

Intermediate Flange Assembly (82878)			
Item No.	Description	Part No.	Qty.
301	Intermediate Flange		1
302	Rollpin		4
303	Breather		1
304	Washer		3
305	Magnetic Plug		1
306	Plug		1
307	Capscrew		8
308	Washer		8

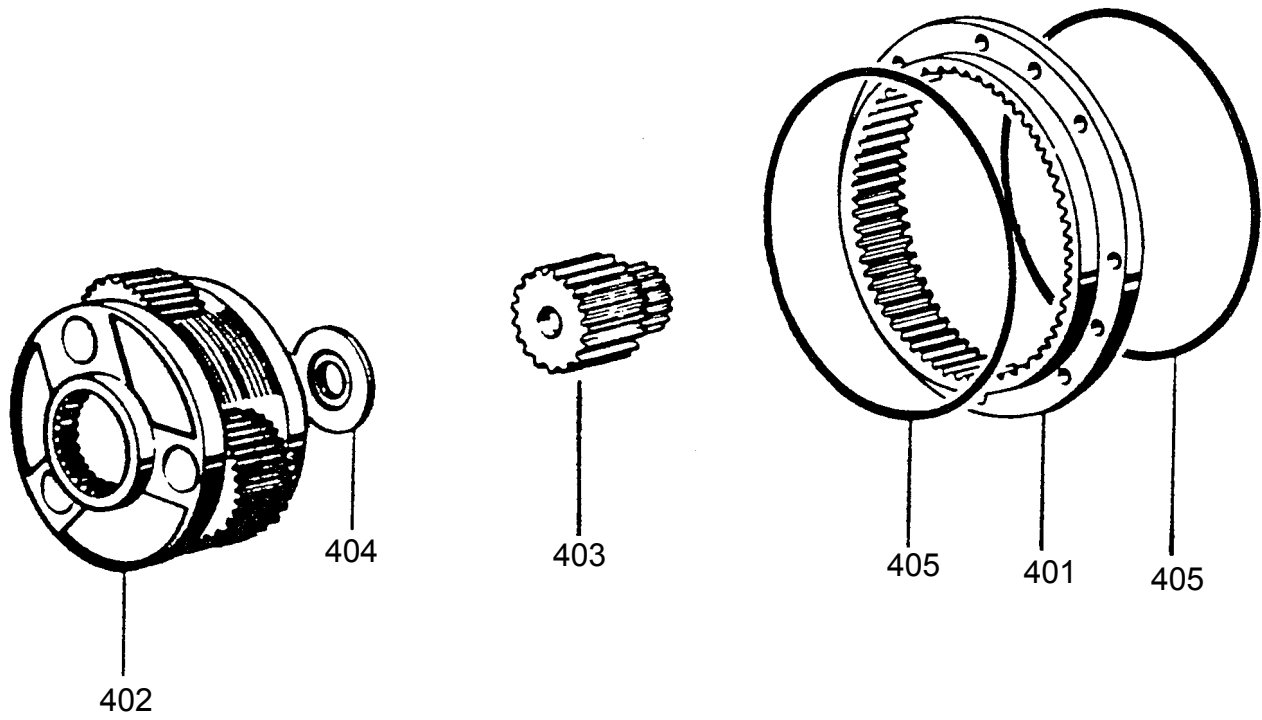

Primary Planet Assembly (82879)			
Item No.	Description	Part No.	Qty.
401	Ring Gear		1
402	Primary Planet Assembly		1
403	Primary Sun Gear		1
404	Thrust Washer		1
405	O-Ring		2

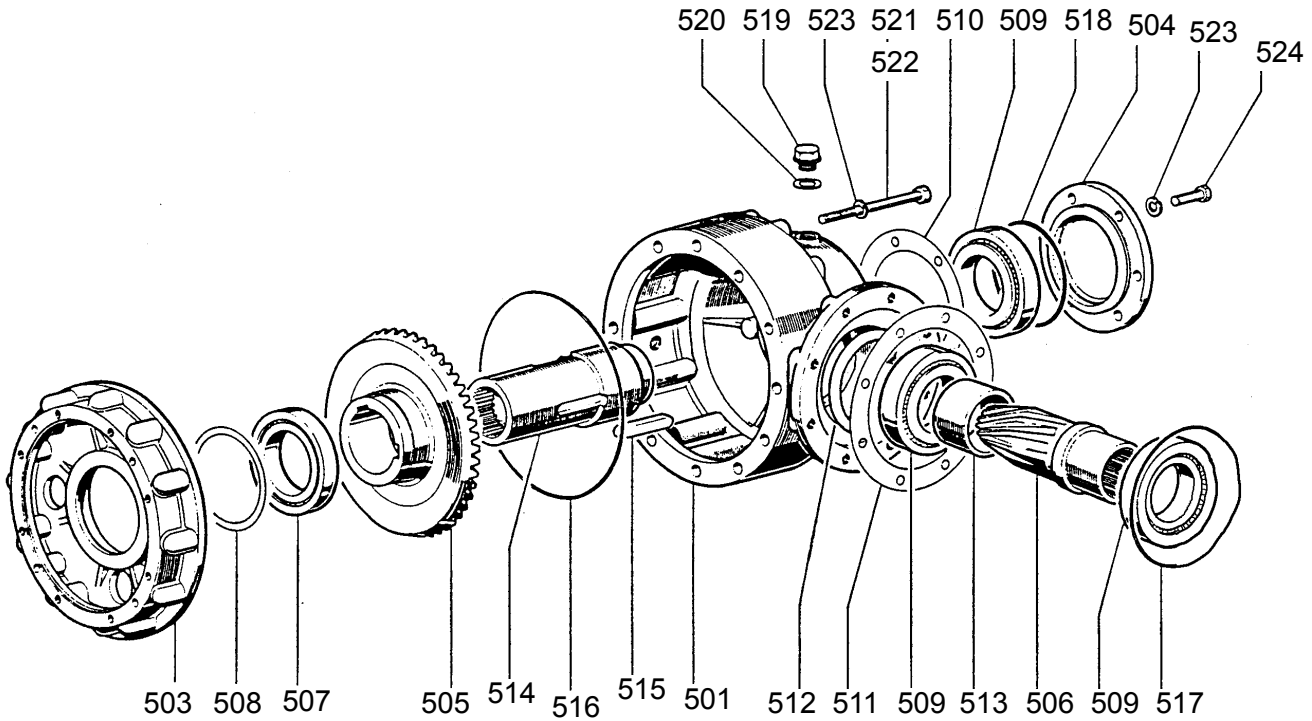

Right Angle Assembly (82890)			
Item No.	Description	Part No.	Qty.
501	Housing		1
503	Adapter Flange		1
504	Input Cover		1
505	Bevel Gear		1
506	Bevel Pinion		1
507	Bearing		1
508	Shim		1
509	Bearing		3
510	Shim		1
511	Shim		1
512	Shim		1
513	Spacer		1
514	Ring Gear Shaft		1
515	Key		2
516	O-Ring		1
517	O-Ring		1
518	O-Ring		1
519	Plug		7
520	Washer		7
521	Capscrew (105 mm long)		9
522	Capscrew (140 mm long)		2
523	Washer		17
524	Capscrew		6

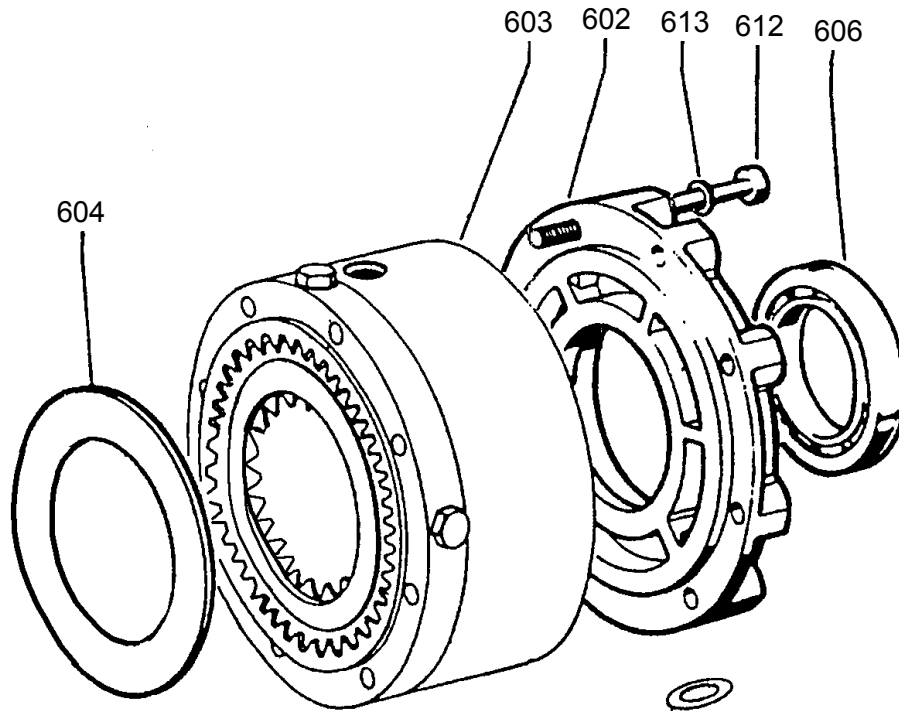

Brake Assembly (82914)			
Item No.	Description	Part No.	Qty.
602	Adapter Flange		1
603	Brake Assembly		1
604	Spacer		1
606	Bearing		2
610	Plug		2
611	Washer		2
612	Capscrew		8
613	Washer		8

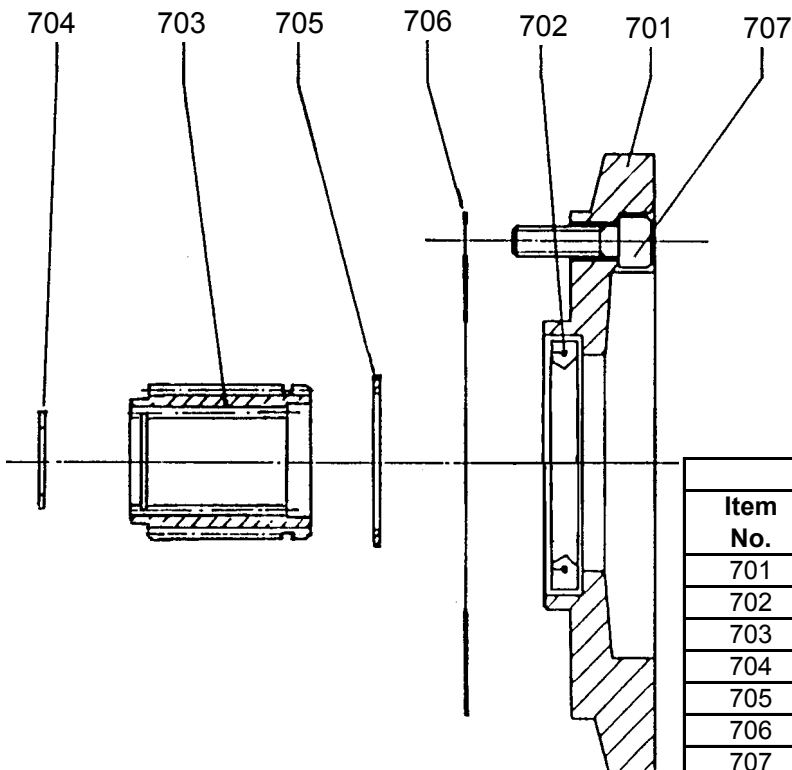

Motor Adapter (82881)			
Item No.	Description	Part No.	Qty.
701	Motor Flange		1
702	Seal		1
703	Motor Coupling		1
704	Retaining Ring		1
705	Retaining Ring		1
706	Gasket		1
707	Capscrew		6