

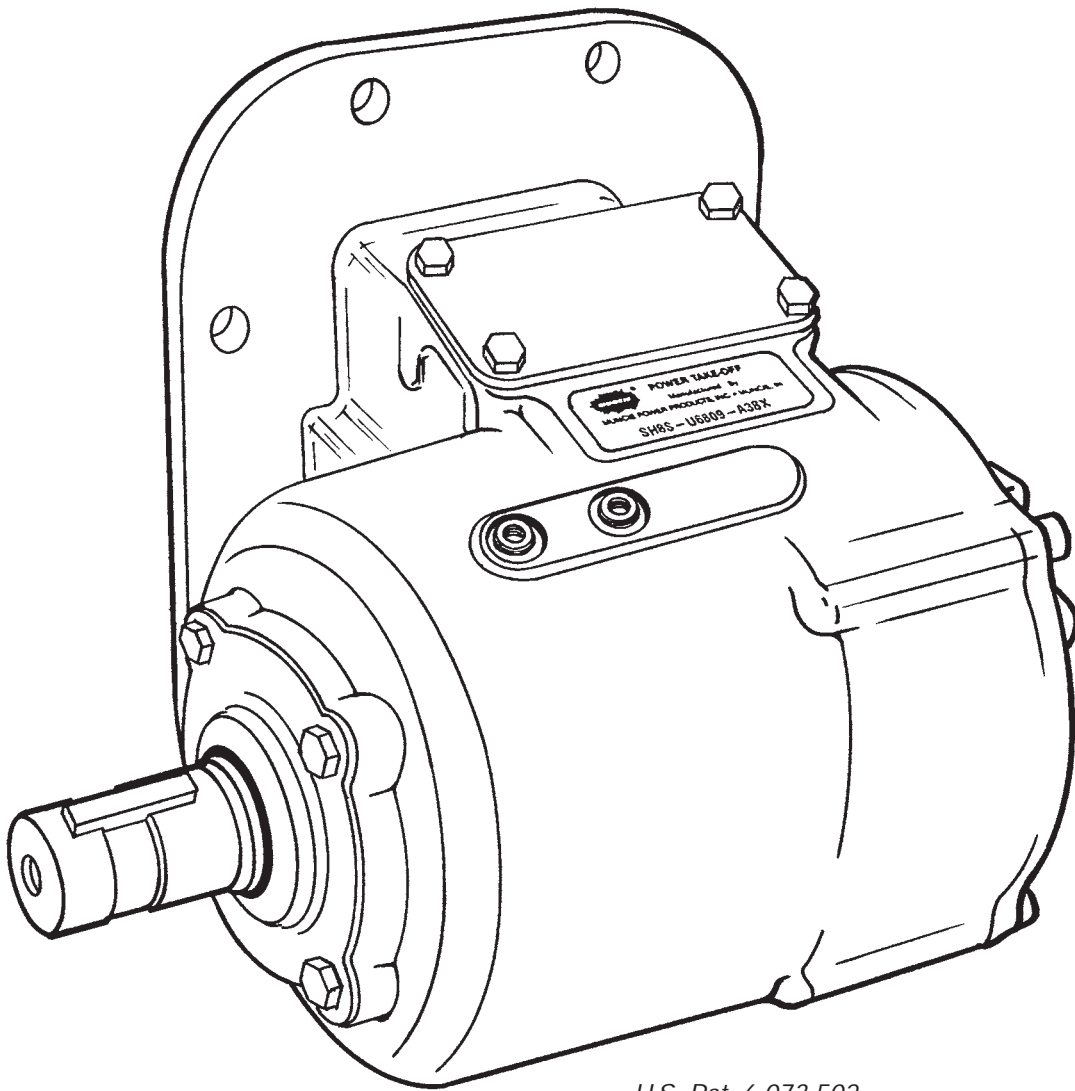

SH6 & SH8 SERIES PTOS

PARTS LIST AND SERVICE MANUAL



U.S. Pat. 6,073,502

SH6 & SH8 SERIES PTO

EXPLODED VIEW

Input Gear Set
See Page 4

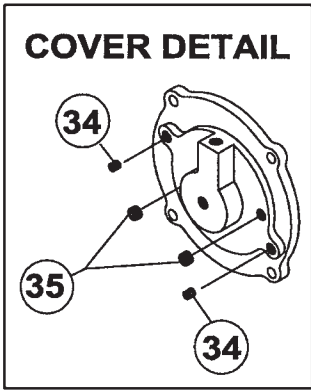
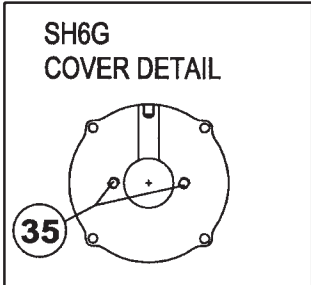
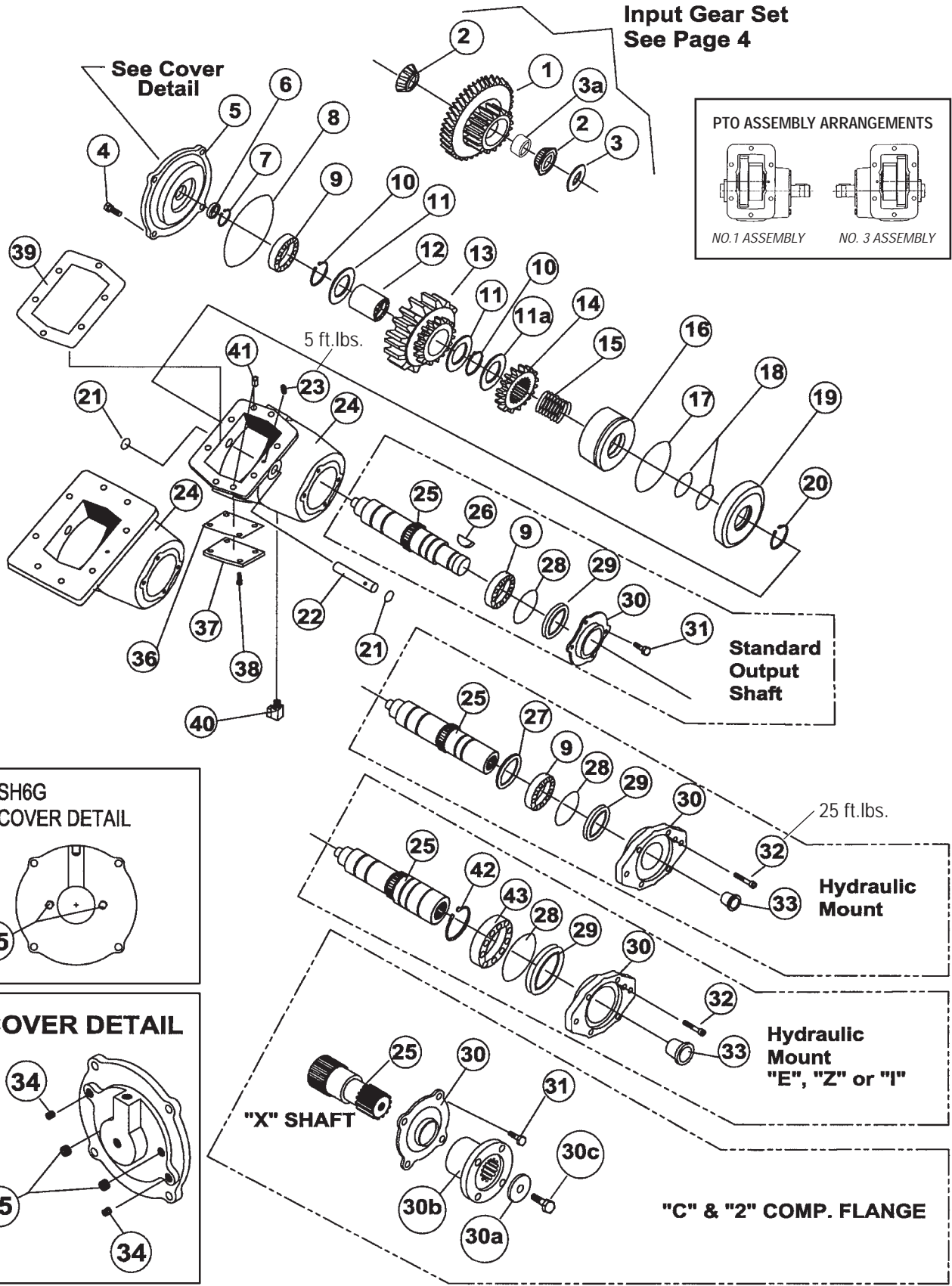

PARTS LIST AND DESCRIPTION

ITEM	QTY	PART NO.	DESCRIPTION
1	1	See Table A	Input Gear
2	2	10T35776	Bearing
3	1	See Table B	Shim
3a	1	See Table C	Cone Spacer
4	4	19T35237	Capscrew
5	1	15T36717	Cover
6	1	11T36124	Seal
7	2	24T36894	Snap Ring
8	1	12T34003	O Ring
9	1	10T21017	Bearing
10	2	24T35480	Snap Ring
11	2	21T29017	Thrust Race (ALL)
11a	1	21T38346	Washer (E, Z or I output only)
12	1	10T36285	Bearing
13	1	02T36769	Output Gear 05 (38)
		02T36770	Output Gear 07 (33)
		02T36771	Output Gear 09 (30)
		02T36772	Output Gear 12 (26)
		02T36773	Output Gear 13 (24)
14	1	02T37707	Clutch Gear
		02T38339	Clutch Gear (E, Z or I output only)
15	1	27T37709	Spring
		27T38342	Spring (E, Z or I output only)
16	1	49T37708	Piston
		49T38340	Piston (E, Z or I output only)
17	1	12T36868	O Ring
		12T36867	O Ring (E, Z or I output only)
18	2	12T36471	O Ring
		12T36053	O Ring (E, Z or I output only)
19	1	49T37710	Piston Cup
		49T38341	Piston Cup (E, Z or I output only)
20	1	24T36470	Snap Ring
		24T36040	Snap Ring (E, Z or I output only)
21	2	12T35774	O Ring
22	1	07T37071	Idler Shaft
23	1	19T35785	Set Screw
24	1	01T37072	Housing 6-Bolt "3" Arng
		01T37073	Housing 6-Bolt "1" Arng
		01T37965	Housing 6-Bolt "3" (F84 input)
		01T37966	Housing 6-Bolt "1" (F84 input)
		01T37074	Housing 8-Bolt "3" Arng
		01T37075	Housing 8-Bolt "1" Arng
		01T38337	Housing 6-Bolt "3" ("I" & "Z" Hyd)
		01T38338	Housing 6-Bolt "1" ("I" & "Z" Hyd)
		01T38350	Housing 8-Bolt "3" ("I" & "Z" Hyd)
		01T38351	Housing 8-Bolt "1" ("I" & "Z" Hyd)
	#	01T38857	Housing 8-Bolt "1" ("E" Hyd)
	#	01T38856	Housing 8-Bolt "3" ("E" Hyd)
25	1	06T36892	Output Shaft "B"
		06T37372	Output Shaft "C" "2" "X"
		06T38718	Output Shaft "E"
		06T37088	Output Shaft "G" Dana Special
		06T38355	Output Shaft "I"
		06T37089	Output Shaft "P"
		06T37090	Output Shaft "Q" "S"
		06T37336	Output Shaft "T"
		06T38345	Output Shaft "Z"
		06T37167	Output Shaft "B" (SH6G)
		06T37168	Output Shaft "K" "V" (SH6G)
26	1	26T01627	Woodruff Key
27	1	28T36546	Hyd. Flange Spacer (K,Q,S,P) (Not used with "I" or "Z")
28	1	12T36751	O Ring
		12T38344	O Ring (E, Z or I output only)
29	1	11T37790	Output Shaft Seal (Std)
		11T37795	Shaft Seal ("E" "I" or "Z" Output)
30	1	15T34576	"B" Bearing Cap
		14T38719	"E" Hyd Flange
		14T38354	"I" Hyd Flange
		14T39137	"G" Hyd Flange
		14T35537	"K" & "P" Hyd Flange
		14T39141	"Q" Hyd Flange
		14T35464	"S" Hyd Flange
		14T37779	"V" Hyd Flange
		14T38343	"Z" Hyd Flange
30a	1	21T20092	Washer ("C", "2" Only)
30b	1	14T37357	"C" Comp. Flange
		14T37378	"2" Comp. Flange

ITEM	QTY	PART NO.	DESCRIPTION
30c	1	19T38266	Capscrew "C", "2", "X"
31	4	19T33233	Hex Capscrew "B" "C" "2" "X"
32	4	19T34462	Socket Capscrew "K" & "P"
		19T39257	Socket Capscrew "G" "Q" "S"
		19T96512	Socket Capscrew "I"
		19T38249	Socket Capscrew "Z"
	8	19M84478	Socket Capscrew "E"
33	1	25T35724	Cap Plug "G" "K" "Q" "S" "V" (Storage Only)
		25T35725	Cap Plug "P"
		25T37767	Cap Plug "I"
		25T35936	Cap Plug "E" or "Z"
34	2	19T36174	Set Screw
35	4	25T21684	Pipe Plug (As Needed)
36	1	13T34022	Insp. Cover Gasket
37	1	16T33999	Inspection Cover
38	4	19T34028	Capscrew
39	1	13M13541	Allison Gasket .031 (U60)
		13M35091	Gasket .010 6-Bolt
		13M35092	Gasket .020 6-Bolt
		13M35151	Gasket .010 8-Bolt
		13M35152	Gasket .020 8-Bolt
40	1	43T37385	Orifice Fitting (P-Special Option)
41	2	26T37992	Dowel Pin (F84 Only)
42	1	24T38347	Snap Ring (E, Z or I Output Only)
43	1	10T21017	Bearing
		10T38248	Bearing (E, Z or I Output Only)
N.S.	1	SH6-GSK	Gasket Kit (Output B,C,G,K,Q,S,V,Z) Includes: (1)6, (1)8, (1)17, (2)18, (2)21, (1)28, (1)29, (1)36, (1)13M35091, (1)13M35092
N.S.	1	SH8-GSK	Gasket Kit (Output B,C,G,K,Q,S,V,Z) Includes: (1)6, (1)8, (1)17, (2)18, (2)21, (1)28, (1)29, (1)36, (1)13M35151, (1)13M35152
N.S.	1	SH6-RBK-A	Rebuild Kit (Output B,C,G,K,Q,S,V,Z) Includes: (1)6, (1)7, (1)8, (2)9, (2)10, (2)11, (1)12, (1)15, (1)17, (2)18, (1)20, (2)21, (1)28, (1)29, (1)36, (1)43 (1)13M35091, (1)13M35092 Input Bearings Included with Input Gear Sub-Ass'y sold separately.
N.S.	1	SH8-RBK-A	Rebuild Kit (Output B,C,G,K,Q,S,V,Z) Includes: (1)6, (1)7, (1)8, (2)9, (2)10, (2)11, (1)12, (1)15, (1)17, (2)18, (1)20, (2)21, (1)28, (1)29, (1)36, (1)43 (1)13M35151, (1)13M35152 Input Bearings Included with Input Gear Sub-Ass'y sold separately.
N.S.	1	SH6-GSK-2	Gasket Kit (Output E,I,Z) Includes: (1)6, (1)8, (1)17, (2)18, (2)21, (1)28, (1)29, (1)36, (1)13M35091, (1)13M35092
N.S.	1	SH8-GSK-2	Gasket Kit (Output E,I,Z) Includes: (1)6, (1)8, (1)17, (2)18, (2)21, (1)28, (1)29, (1)36, (1)13M35151, (1)13M35152
N.S.	1	SH6-RBK-A2	Rebuild Kit (Output E,I,Z) Includes: (2)2, (1)6, (1)7, (1)8, (2)9, (2)10, (2)11, (1)12, (1)15, (1)17, (2)18, (1)20, (2)21, (1)28, (1)29, (1)36, (1)42 (1)43, (1)13M35091, (1)13M35092 Input Bearings Included with Input Gear Sub-Ass'y sold separately.
N.S.	1	SH8-RBK-A2	Rebuild Kit (Output E,I,Z) Includes: (2)2, (1)6, (1)7, (1)8, (2)9, (2)10, (2)11, (1)12, (1)15, (1)17, (2)18, (1)20, (2)21, (1)28, (1)29, (1)36, (1)42 (1)43, (1)13M35151, (1)13M35152 Input Bearings Included with Input Gear Sub-Ass'y sold separately.
SUB-ASSEMBLIES USED IN PACKAGING OF PTO			
48TK3991 Shift Option Code "A" Manual Air Valve Type. Includes:			
	1	20MK8800	Stud Kit
	1	48TK3926	12v Manual Air
	1	45M44430	Tubing 30 Ft.
	1	36MK3841	Safety Labels
48TK3961 Shift Option Code "E" Electric/Air 12vdc. Includes:			
	1	20MK8800	Stud Kit
	1	48TK3958	SH6/8 12vdc "E"
	1	45M44430	Tubing 30 Ft.
	1	36MK3841	Safety Labels

MODEL NUMBER CONSTRUCTION

SH 6S — M65 07 — E 1 B X

PTO Type

SH

Mounting

SAE 6 Bolt Std. Mount	— 6S
SAE 6 Bolt Std. - Metric	— 6B
SAE 6 Bolt Deep - Metric	— 6C
SAE 6 Bolt Deep Mount	— 6D
SAE 6 Bolt Deep Mount w/o Stud Kit	— 6K
SAE 6 Bolt Std. Mount w/o Stud Kit	— 6L
SAE 8 Bolt Std. Mount	— 8S
SAE 8 Bolt Std. - Metric	— 8B
SAE 8 Bolt Deep - Metric	— 8C
SAE 8 Bolt Deep Mount	— 8D
SAE 8 Bolt Deep Mount w/o Stud Kit	— 8K
SAE 8 Bolt Std. Mount w/o Stud Kit	— 8L

Trans. SH Gear Data

Fuller	10.1P 20°PA Spur	— F10
Fuller	1.01P 21.5°PA Spur	— F11
Fuller	8.38P 17.5°PA 33.09° LH	— F84
Fuller	8.38P 17.5°PA 33.09° RH	— F86
Mack	6.48P 17.65°PA Spur	— M65
Spicer	6P 17.5°PA 26.17° LH	— S60
Spicer	6 or 6/8P 20°PA Spur	— S68
Spicer	7P or 17.5°PA 28.07° LH	— S70
Universal	6P 20°PA Spur	— U60
Universal	6 or 6/8P 20°PA Spur	— U68

Speed Ratio

05 — .47:1 09 — .87:1 13 — 1.33:1 (8 Bolt Only)
07 — .70:1 12 — 1.15:1

Special Feature

X — None
P — Pressure Lube
R — Pulse Generator/No Pres. Lube
S — Pulse Generator/Pres. Lube

Output Type

B — 1-1/4 Round 5/16 KW
C — 1410 Companion Flange
E — SAE "C" 2&4 Bolt
G — Special
I — DIN 5462
K — SAE "B" 2 & 4 Bolt
P — SAE "BB" 2 & 4 Bolt
Q — SAE "A" 2 Bolt
S — SAE "B" 2 Bolt
T — SAE "A" 3/4" 11 Spl. 2 Bolt
V — SAE "B" 2 & 4 Bolt
X — 1.3-21 Spline
Z — SAE "B" w/1-1/4 -14T Shaft
2 — DIN Companion Flange

Assembly Arrangement

1 3 (see page 2)

Shifter Type

A — Manual Air M — Constant Mesh
E — Electric/Air (12 Volt) P — Less Activation Components
F — Electric/Air (24 Volt)

OUTPUT LOAD RATINGS

SPEED RATIO	TORQUE LBS.FT.	HP @1000 RPM	TORQUE NM	KW @1000 RPM
05	400	76	542	57
07	400	76	542	57
09	375	71	508	53
12	325	62	441	46
13	325	62	441	46

TABLE A - ITEM #1 INPUT GEAR Service Parts Sold as Sub-Assy Only

SUB-ASS'Y	INPUT GEAR	DESCRIPTION (#T)
03TA4561	03T37984	Input Gear F1012 (42/30)
03TA4562	03T37985	Input Gear F1013 (42/32)
03TA4563	03T37156	Input Gear F1107 (42/23)
03TA4564	03T37157	Input Gear F1113 (42/32)
03TA4565	03T37742	Input Gear F8407 (28/23)
03TA4566	03T37743	Input Gear F8409 (28/26)
03TA4680	03T39447	Input Gear F8607 (28/23)
03TA4568	03T37070	Input Gear M6505 (26/18)
03TA4569	03T37058	Input Gear M6507 (26/23)
03TA4570	03T37059	Input Gear M6509 (26/26)
03TA4571	03T37060	Input Gear M6512 (26/30)
03TA4572	03T37061	Input Gear S6007 (21/23)
03TA4573	03T37062	Input Gear S6807 (26/23)
03TA4574	03T37063	Input Gear S6809 (26/26)
03TA4575	03T37064	Input Gear S6812 (26/30)
03TA4576	03T37158	Input Gear S6813 (26/32)
03TA4580	03T37069	Input Gear U6005 (24/18)
03TA4581	03T37038	Input Gear U6807 (24/23)
03TA4582	03T37039	Input Gear U6809 (24/26)
03TA4583	03T37040	Input Gear U6812 (24/30)
03TA4584	03T37041	Input Gear U6813 (24/32)

Sub-Assy includes Input Gear, measured cone spacer, input bearings. Requires input gear shim item #3 (Table B) for proper installation, purchase shim kit 18TK4586 sold separately.

TABLE B - ITEM #3 BEARING SHIM

SHIM	DESCRIPTION	NOMINAL	TOLERANCE
18T35783	Bearing Shim	0.114	0.1150 / 0.1130
18T38725	Bearing Shim	0.116	0.1175 / 0.1155
18T35782	Bearing Shim	0.119	0.1200 / 0.1180
18T38726	Bearing Shim	0.121	0.1225 / 0.1205
18T35781	Bearing Shim	0.124	0.1250 / 0.1230
18T38727	Bearing Shim	0.126	0.1275 / 0.1255
18T36230	Bearing Shim	0.129	0.1300 / 0.1280
18T38728	Bearing Shim	0.131	0.1325 / 0.1305
18T36229	Bearing Shim	0.134	0.1350 / 0.1330
18T38729	Bearing Shim	0.136	0.1375 / 0.1355
18T37151	Bearing Shim	0.139	0.1400 / 0.1380
18T38730	Bearing Shim	0.141	0.1425 / 0.1405
18T37152	Bearing Shim	0.144	0.1450 / 0.1430
18T38731	Bearing Shim	0.146	0.1475 / 0.1455
18T37153	Bearing Shim	0.149	0.1500 / 0.1480

Shim Kit 18TK4586 (Incl 1 ea of every item #3 shim)

TABLE C - ITEM #3A CONE SPACER

SPACER	DESCRIPTION	DIMENSION
18T38640	Cone Spacer	0.983 / 0.981
18T38641	Cone Spacer	0.980 / 0.978
18T38642	Cone Spacer	0.977 / 0.975
18T38643	Cone Spacer	0.974 / 0.972
18T38644	Cone Spacer	0.971 / 0.969
18T38635	Cone Spacer	0.998 / 0.996
18T38636	Cone Spacer	0.995 / 0.993
18T38637	Cone Spacer	0.992 / 0.990
18T38638	Cone Spacer	0.989 / 0.987
18T38639	Cone Spacer	0.986 / 0.984
18T38645	Cone Spacer	0.968 / 0.966
18T38646	Cone Spacer	0.965 / 0.963
18T38647	Cone Spacer	0.962 / 0.960
18T38648	Cone Spacer	0.959 / 0.957
18T38649	Cone Spacer	0.956 / 0.954

SH6 & SH8 DIMENSIONS IN INCHES (MM)

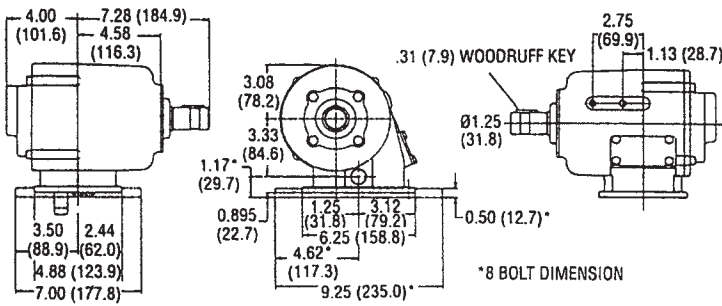

SH6/8S HOUSING DIMENSION

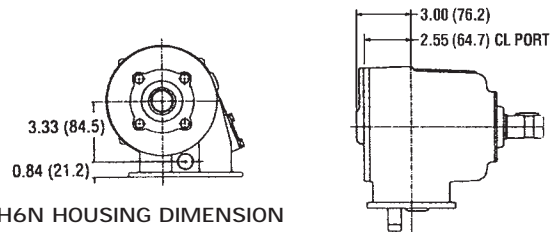

SH6N HOUSING DIMENSION

SH6G HOUSING OPTION "B" OR "K" SHAFT ONLY.

STANDARD 1-1/4" ROUND KEYED SHAFT ("B" OPTION)

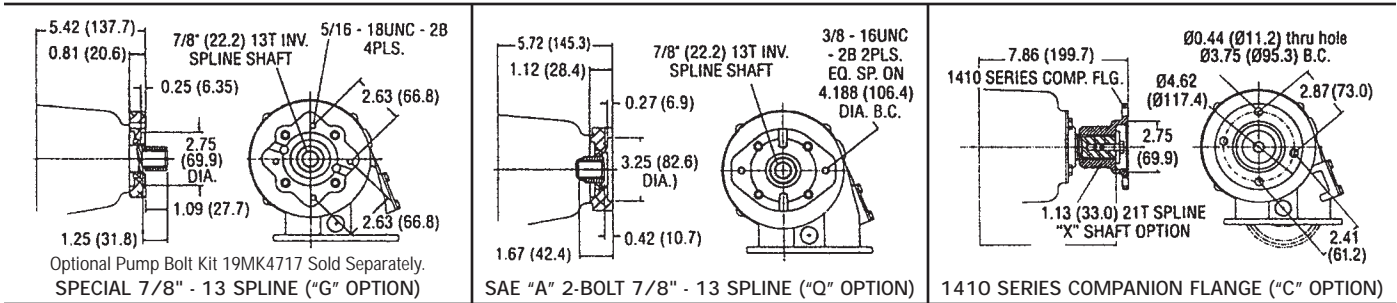

Optional Pump Bolt Kit 19MK4717 Sold Separately.
SPECIAL 7/8" - 13 SPLINE ("C" OPTION)

SAE "A" 2-BOLT 7/8" - 13 SPLINE ("Q" OPTION)

1410 SERIES COMPANION FLANGE ("C" OPTION)

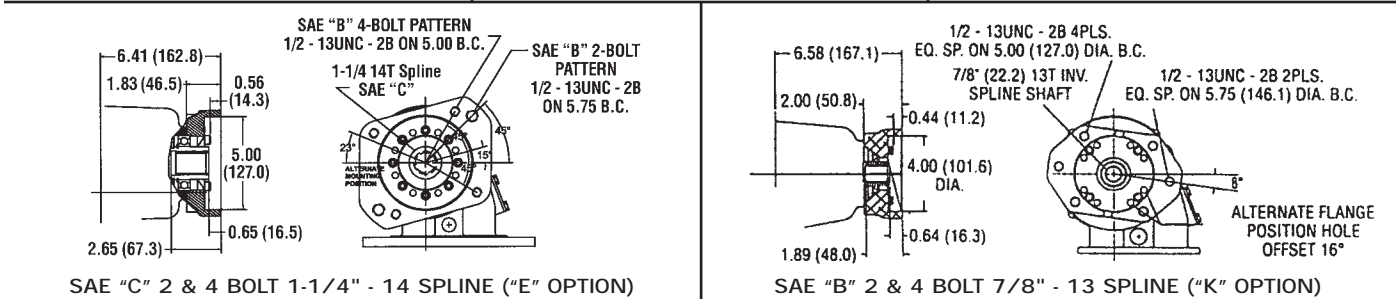

SAE "C" 2 & 4 BOLT 1-1/4" - 14 SPLINE ("E" OPTION)

SAE "B" 2 & 4 BOLT 7/8" - 13 SPLINE ("K" OPTION)

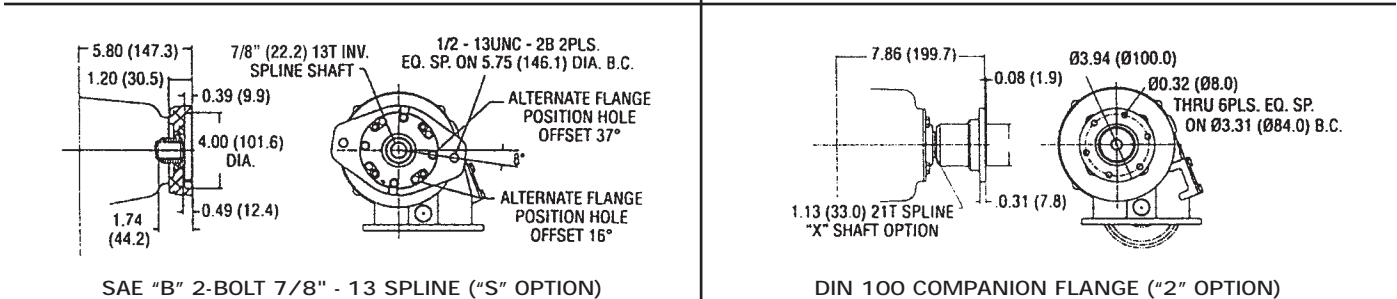

SAE "B" 2-BOLT 7/8" - 13 SPLINE ("S" OPTION)

DIN 100 COMPANION FLANGE ("2" OPTION)

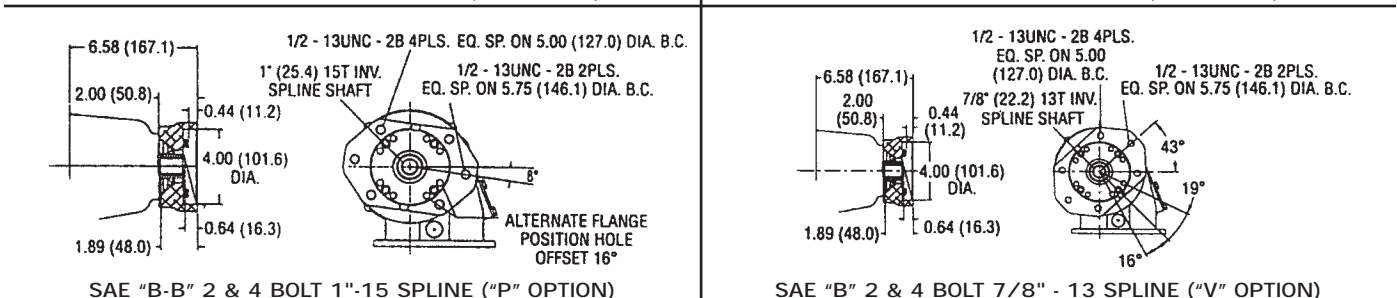

SAE "B-B" 2 & 4 BOLT 1" - 15 SPLINE ("P" OPTION)

SAE "B" 2 & 4 BOLT 7/8" - 13 SPLINE ("V" OPTION)

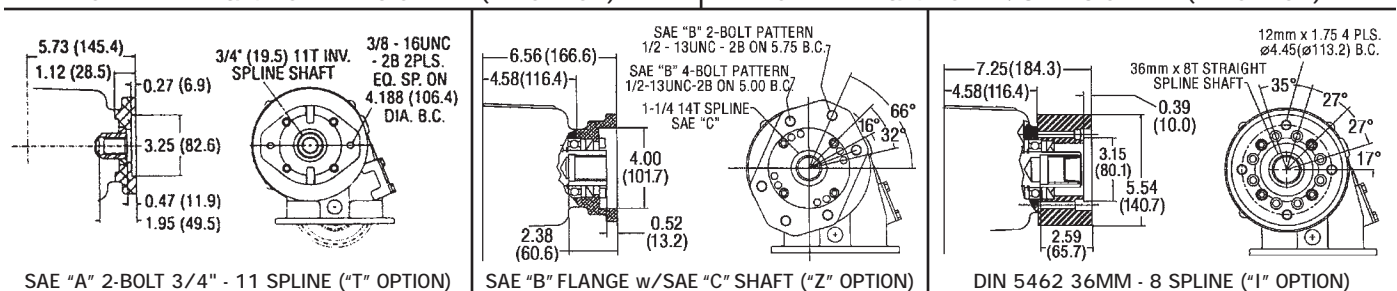

SAE "A" 2-BOLT 3/4" - 11 SPLINE ("T" OPTION)

SAE "B" FLANGE w/SAE "C" SHAFT ("Z" OPTION)

DIN 5462 36MM - 8 SPLINE ("1" OPTION)

SH6 & SH8 ASSEMBLY INSTRUCTIONS

FOR PROPER INSTALLATION AND ADJUSTMENT OF THE TAPERED INPUT BEARINGS

The input gear must be purchased as a kit which includes the input gear, bearings and bearing (cone) spacer. This must remain as a group and not interchanged with any other gears.

1. Lubricate bearings and races with lithium based bearing grease.
2. Place the input gear set (with bearings and cone spacer) into the housing and line up with the idler shaft. Position the idler shaft so that the set screw hole aligns with the PTO housing set screw location.
3. Tap the idler shaft into the housing and through both bearing races.
4. Tap the idler shaft in the reverse direction so that it is just below the surface of the bearing in this assembly. Insert the thickest shim that can be installed **by hand** in the gap between the bearing and the housing. Rotate the input gear to ensure it is not excessively tight or loose. Remove this shim and insert the next larger shim between the bearing and the housing. This will require that you drive this shim into place. Recommended bearing clearance pre-load is .002" loose to .006" loose. Note the location of the shim, it is on the opposite side of the gear than the set screw.
5. Tap the idler shaft into position and install the set screw.

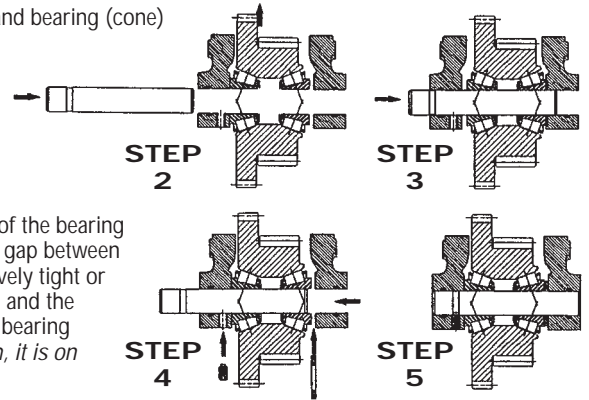

Note the location of the Shim in Step #4 is on the opposite side of the gear than the set screw.

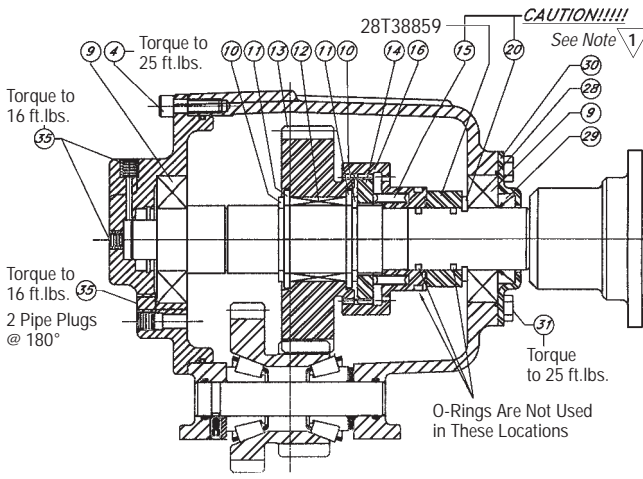

CONSTANT MESH OPTION

- 1 CAUTION: WHEN ASSEMBLING OR DISASSEMBLING THESE PARTS!!! Approximately 130 lbs force is required to compress spring (Item 15) and install spacer (Item 28T38859) and snap ring (Item 20) on shaft (Item 32).

The Constant Mesh version of the SH Series is accomplished by inserting a spacer, P.N. 28T38859, in place of the piston cup. Disassemble the SH Series output shaft assembly and remove the piston cup and o-rings and assemble the unit as shown above. Plug all pipe ports with appropriate plugs before installing unit.

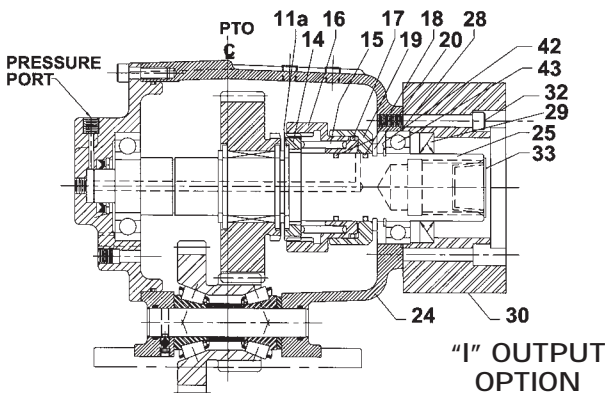
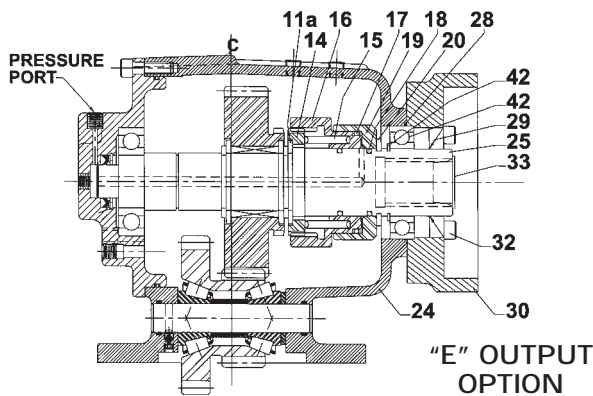

ITEM	QTY	PART NO.	DESCRIPTION
11a	1	21T38346	Washer
14	1	02T38339	Gear, Clutch
15	1	27T38342	Spring
16	1	49T38340	Piston
17	1	12T36867	O'Ring
18	2	12T36053	O'Ring
19	1	49T38341	Piston Cup
20	1	24T36040	Snap Ring
24	1	See Pg 3	Housing
25	1	06T38355	Shaft "I"
	1	06T38345	Shaft "Z"
	1	06T38718	Shaft "E"
28	1	12T38344	O'Ring
29	1	11T37795	Seal
30	1	14T38354	Adapter "I"
	1	14T38343	Adapter "Z"
	1	14T38719	Adapter "E"
32	4	19T96512	Cap Screw "I"
	4	19T38249	Cap Screw "Z"
	8	19M84478	Cap Screw "E"
33	1	25T37767	Caplug "I"
	1	25T35936	Caplug "E" "Z"
42	1	24T38347	Snap Ring
43	1	10T38248	Bearing

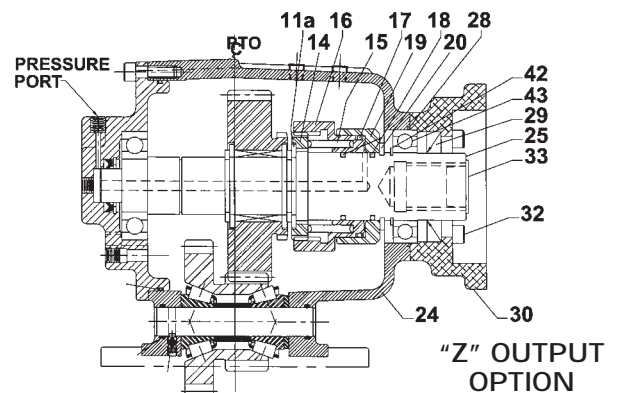

MOUNTING KITS

6-BOLT MOUNTING KIT

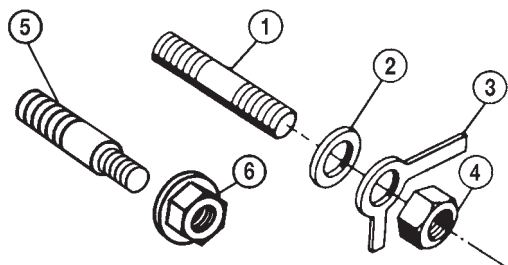

20TK4418 STANDARD (SH6S, SH6D)

ITEM	QTY	PART NUMBER	DESCRIPTION
1	4	20M38150	Stud
2	4	13M18018	Copper Gasket
3	4	21MX3802	Lock Tab
4	4	22MX3824	Nut
5	2	20T37032	Step-Stud
6	2	22T37605	Lock Nut
N.S.	1	MC00-02	Instruction Card

20TK4359 METRIC (SH6B, SH6C)

1	4	20M39040	Stud
2	4	13M18018	Copper Gasket
3	4	21MX3802	Lock Tab
4	4	22MX3824	Nut
5	2	20T37952	Step-Stud
6	2	22T37605	Lock Nut
N.S.	1	MC00-02	Instruction Card

20TK4360 METRIC (SH6B-A6907)

1	4	20M39045	Stud
2	4	13M18018	Copper Gasket
3	4	21MX3802	Lock Tab
4	4	22MX3824	Nut
5	2	20T38391	Step-Stud
6	2	22T37605	Lock Nut
N.S.	1	MC00-02	Instruction Card

20TK4074 METRIC (SH6B-184)

1	6	20T37990	Stud
2	6	13M18018	Copper Gasket
3	6	21MX3802	Lock Tab
4	6	22MX3824	Nut

20TK4046 METRIC (SH6F-F84)

1	4	20M39040	Stud
2	4	13M18018	Copper Gasket
3	4	21MX3802	Lock Tab
4	4	22MX3824	Nut
5	2	20T39529	Step-Stud
6	2	22T37605	Lock Nut
N.S.	1	13M51717	Locktite GSK Elim
N.S.	1	MC99-06	Instruction Card

8-BOLT MOUNTING KIT

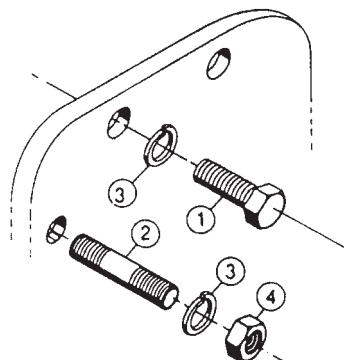

20MK8800 STANDARD (SH8S, SH8D)

ITEM	QTY	PART NUMBER	DESCRIPTION
1	6	19M44138	Capscrew
2	2	20M44175	Stud
3	8	21ML4375	Lockwasher
4	2	22MX4420	Nut

20MKM801 METRIC (SH8B, SH8C)

2	8	20M47050	Stud
3	8	21ML4375	Lockwasher
4	8	22MX4420	Nut

LUBE HOSE KITS

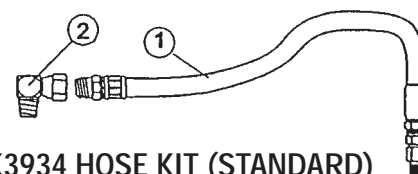

43TK3934 HOSE KIT (STANDARD)

ITEM	QTY	PART NUMBER	DESCRIPTION
1	1	45M4R536	Hose Assembly Std.
2	1	43M05522	Elbow

SH6 & SH8 SERIES PTO

The SH6 & SH8 Series PTO offers several output shaft choices to accommodate popular pump assemblies. The compact size and high torque capability of the SH PTO permits direct mounting pumps which previously required remote mount. The SH Series PTO is available with pulse generator pick-up for use with the Muncie digital tachometer 38MK2000 (request MP92-04). Contact your Muncie Application Specialist for assistance with this option.



SP97-01 (Rev. 6-04) Printed in the U.S.A.
© Muncie Power Products, Inc. 2004

Muncie Power Products, Inc. Member of the Interpump Hydraulics Group
General Offices and Distribution Center • P.O. Box 548 • Muncie, IN 47308-0548
(765) 284-7721 • FAX (765) 284-6991 • E-mail info@munciepower.com
Web site <http://www.munciepower.com>

Drive Products, Inc., Toronto, Exclusive Agents for Canada, ISO Certified by an Accredited Registrar

